

INSTRUCTION MANUAL

CL-75

Centre Lathe (415V)

560 x 2000mm

Includes Taper Turning Attachment



L626

OPERATION MANUAL

CONTENTS

SPECIFICATION.....	1
1. High Speed Precision Lathe	
1-1 Constructional Indication	2
2. Unpacking and Installation	
2-1 Points for Unpacking	4
2-2 Unloading of the Machine	4
2-3 Construction of the Ground	5
2-4 Cleaning	5
2-5 Level Adjustment	5
3. Electric Circuit Control	
3-1 Electric Wiring.....	7
3-2 Electric Device.....	7
3-3 Important Notes.....	7
4. Test Running	
4-1 Operation Symbols	13
4-2 Transmission and Stop of Main Spindle	14
4-3 Selecting Main Spindle Speed.....	14
4-4 "INTERMITTANT" Operation of Main Spindle	15
4-5 The Importance and Methods of Spindle Levelling Adjustment.....	15
4-6 Transmission and Stop of Gear Box	16
4-7 Operation of Gear Box	16
4-8 Manual Operation.....	16
4-9 Auto Feed Operation	17
4-10 Auto Feed Stop Operation	17

4-11 Four Position Auto Feed Stop Operation	18
4-12 Tailstock Operation	18-19
5. Cutting Threads	
5-1 Leadscrew Drive	20
5-2 Cutting Thread.....	20
5-3 Thread Dial Indicator.....	20-21
5-4 Thread and Feed Table.....	22-25
6. Lubrication	
6-1 Lubrication in Headstock.....	26
6-2 Lubricating in Gear Box and Apron	26
6-3 Useful Reference Lubricating Table for other Mechanism.....	26-27
6-4 Lubrication Location.....	28
7. Maintenance & Servicing	
7-1 Headstock	29
7-2 Apron & Saddle.....	30
7-3 Gear Box.....	31
7-4 Adjustment of Tailstock Centering	32
7-5 Belt Tension Adjustment	32
7-6 Foot Brake Belt Adjustment.....	33
7-7 Brake and Micro Switch Adjustment	33
7-8 Adjustment to the Backlash of Leadscrew.....	33-34
7-9 Maintenance for Cutting Liquid Coolant Pump	34
8. CHUCKS AND CHUCK MOUNTING	35
9. PREVENTIVE MAINTENANCE	36-39
10. TROUBLE SHOOTING	40-42
11. Parts List Assembly	43-76

SPECIFICATION

MODELS

C6251A×1500 / C6251A×2000

Capacity	510mm
Swing Over Bed	300mm
Swing Over Cross Slide	738×200mm
Swing In Gap Diameter×Width	255mm
Height of Center	1515mm / 2010mm
Distance Between Centers	350mm
Width of Bed	25×25mm
Cutting Tool Max. Section	326mm
Total Travel of Cross Slide	130mm
Total Travel Of Top Slide	

Headstock

Spindle Bore	Φ80mm
Spindle Nose	D1-8
Spindle Morse Taper In Nose, In Sleeve	MT7 [#]
Spindle Speeds Number	12
Spindle Speeds Range	25-1600r.p.m

Thread & Feeds

Leadscrew Diameter & Thread	40mm×4T.P.I.or Pitch 6mm
Threads Imperial Pitches	2-112 T.P.I. (60nos)
Threads Metric Pitches	0.2-14mm (47nos)
Diametrical Pitches	4-112D.P.(50nos)
Module Pitches	0.1-7M.P.(39nos)
Longitudinal Feeds Imperial	0.0022"-0.0612"/Rev (35nos)
Longitudinal Feeds Metric	0.059-1.646mm/Rev (35nos)
Cross-Feeds Imperial	0.00048"-0.01354"(35nos)
Cross Feeds Metric	0.020-0.573mm(35nos)

Tailstock

Total Travel Of Tailstock Quill	180mm
Tailstock Quill Diameter	75mm
Taper In Tailstock Quill	M.T.No.5

Motor

Spindle Drive Motor	7.5kw(10HP) 3PH
Coolant Pump Motor	0.1kw(1/8HP)

Weight & Measures

Machine Space Required (L×W×H): cm	284x115x143 / 334x115x143
Packing Case Dimensions (L×W×H): cm	290x115x174 / 340x115x174
Net Weight	2335kg / 2685kg
Gross Weight	2700kg / 3070kg

SPECIFICATION

MODELS	C6256A×1500 / C6256A×2000
Capacity	
Swing Over Bed	560mm
Swing Over Cross Slide	350mm
Swing In Gap Diameter×Width	788×200mm
Height of Center	280mm
Distance Between Centers	1515mm / 2010mm
Width of Bed	350mm
Cutting Tool Max. Section	25×25mm
Total Travel of Cross Slide	326mm
Total Travel Of Top Slide	130mm
Headstock	
Spindle Bore	Φ80mm
Spindle Nose	D1-8
Spindle Morse Taper In Nose, In Sleeve	MT7 [#]
Spindle Speeds Number	12
Spindle Speeds Range	25-1600r.p.m
Thread & Feeds	
Leadscrew Diameter & Thread	40mm×4T.P.I.or Pitch 6mm
Threads Imperial Pitches	2-112 T.P.I. (60nos)
Threads Metric Pitches	0.2-14mm (47nos)
Diametrical Pitches	4-112D.P.(50nos)
Module Pitches	0.1-7M.P.(39nos)
Longitudinal Feeds Imperial	0.0022"-0.0612"/Rev (35nos)
Longitudinal Feeds Metric	0.059-1.646mm/Rev (35nos)
Cross-Feeds Imperial	0.00048"-0.01354"(35nos)
Cross Feeds Metric	0.020-0.573mm(35nos)
Tailstock	
Total Travel Of Tailstock Quill	180mm
Tailstock Quill Diameter	75mm
Taper In Tailstock Quill	M.T.No.5
Motor	
Spindle Drive Motor	7.5kw(10HP) 3PH
Coolant Pump Motor	0.1kw(1/8HP)
Weight & Measures	
Machine Space Required (L×W×H): cm	284x115x143 / 334x115x143
Packing Case Dimensions (L×W×H): cm	290x115x174 / 340x115x174
Net Weight	2335kg / 2685kg
Gross Weight	2700kg / 3070kg

HIGH SPEED PRECISION LATHE

1-1 Constructional Indication

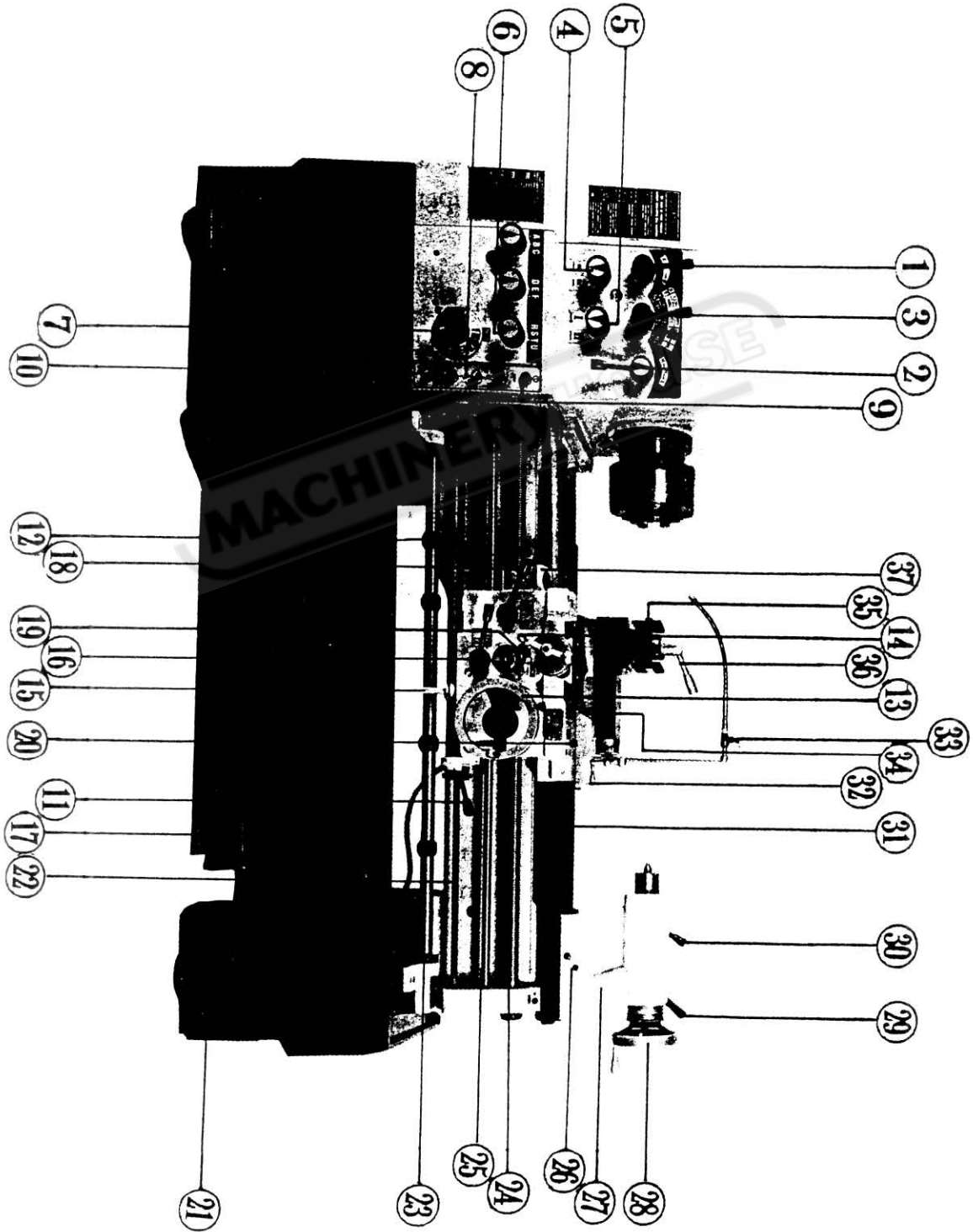

No.	Description	No.	Description
1	Main Spindle Speed Change Lever	20	Saddle Fixture Screws
2	High/Low Speed Change Lever	21	Foundation Adjustment Bolts
3	Main Spindle Speed Select Lever	22	Start Lever
4	Forward/Reverse Lever	23	+Position Auto Stop Lever
5	Thread Feed Select Lever	24	Leadscrew
6	Thread Feed Change Lever	25	Auto Feed Rod
7	10 Steps Feed Change Disc	26	Tailstock Set Over Adjust Screws
8	Power Switch	27	Tailstock Body
9	Intermittent Switch	28	Tailstock Handwheel
10	Coolant Pump Switch	29	Tailstock Body Clamping Lever
11	Start Spindle Control Knob	30	Tailstock Spindle Locking Lever
12	Eccentric Center Ring	31	Rack
13	Longitudinal Apron Handwheel	32	Compound Rest Handle
14	Cross Slide Feed Knob	33	Coolant Control Valve
15	Auto Stop Centering	34	Compound Rest
16	Auto Feed Lever	35	Four Way Tool Post
17	Foot Brake Pedal	36	Tool Post Clamping Lever
18	Half Nut Engaged Lever	37	Thread Dial Indicator
19	Feed Select Lever (Longitudinal & Cross Feed)	38	Adjust Screws of Gib

2.Unpacking and Installation

2-1 Points for Unpacking

For short distance transportation of this machine, fix it onto the truck by hemp rope; while for long distance, packed by a wooden case or despatched by container. Please first to check if there is any damage on packing when arrive. After unpacking, carefully inspect whether it exists any injury or insufficiency. If any, contact us immediately for proper settlement or any of the damages of the machine will receive no any compensation from us.

2-2 Unloading of the Machine

When the machine is unloaded from the car or to be moved, please proceed with following steps (as illustrated 2-2)

- 1) Preparing two round sticks (long approx.830m/m dia 40m/m)insert into the preserved holes on lathe bed. Then lift up with applying wires on both end of the stick.
- 2) Lifting the machine by a crane.
- 3) Before lifting,adjust the position of Lathe Apron and Tailstock to maintain the balance of machine.
- 4) When the machine was shifted to its destination,always handle with care to put it down. Don't let go of it to hit the ground or it will affect the accuracy of the machine.

Note: Machine weight can be seen in Specification Table.

- 5) For the adjustment of electric control,keep the distance between machine and wall not less than 600 mm.

illustration 2-2

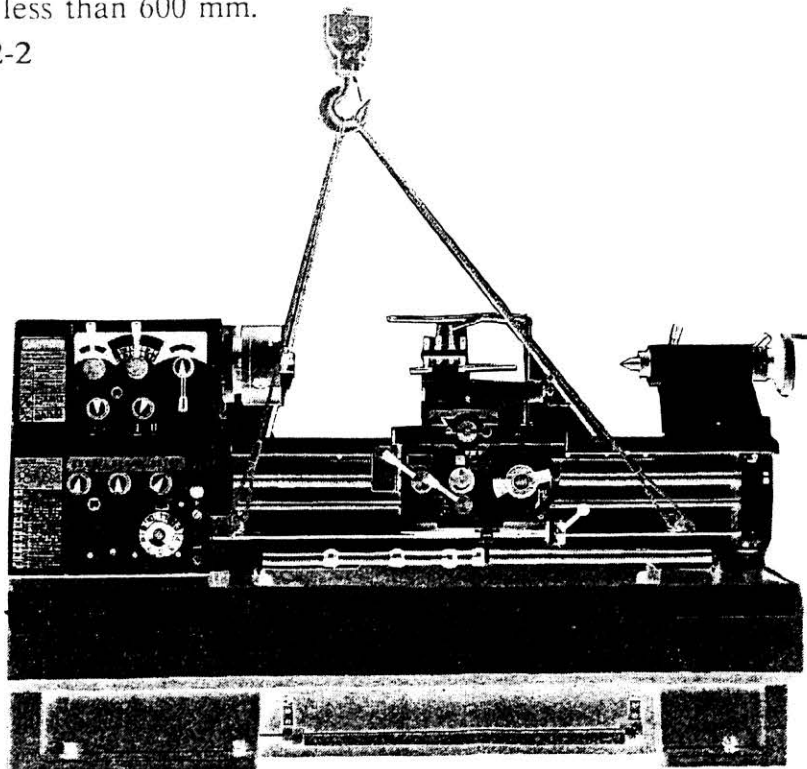

2-3 Construction of the Ground

Due to the recent tendency of utilizing Utilizing Ultra-Hard Alloy Steel tools, it surely increase the speed of heavy cutting comparing to the previous steel tools. But, in the mean time, it easily happens to the vibration of the machine. For assuring better cutting result, it requires a very strong and steady construction of ground. (Please refer to right illustration of constructin of ground)

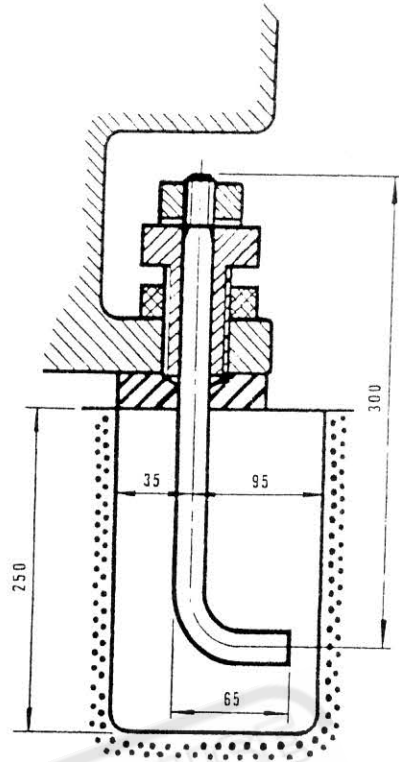

2-4 Cleaning

All our machine are with a anti-rust oil layer before delivery. After inspection, please remove to clean the slideways, leadscrew, shafts and other polished parts by a soft cloth with cleanser (do not use gasoline or cellulose solvent to avoid fire or explosion). Then apply a thin layer of oil for lubricating purpose. Push those movable parts such as: Tool Holder, Tailstock back and forth.

2-5 Level Adjustment

Wait until the fixture screws and cement completely concrete to start adjusting lathe bed horizontally. In doing this, place a leveling instrument (with accuracy 0.02 mm/1000 mm) upon the grooves of lathe bed to confirm the level of right and left side. Same procedure for the front and rear leveling.

The allowance of level should be adjusted within 0.04 mm/1000 mm.

Screw up the nuts, check again, if whatever errors occur due to tightly screw-up thereafter, adjustment may required to be done again.

As per illustration indicated, place two leveling instruments on lathe bed to check the level by pushing them back and forth in its possible maximum moving range.

2-5

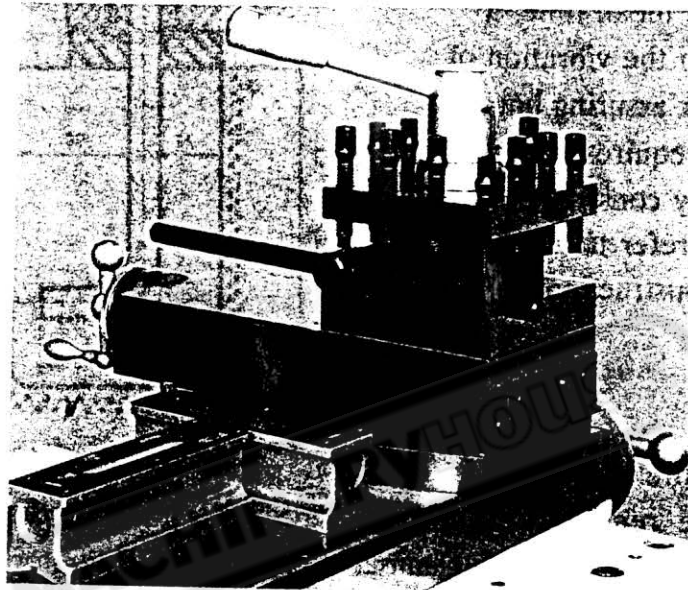

3. Electric Circuit Control

3-1 Electric Wiring

You can find the electric control box by open the metal cover behind the lathe bed. Connect the terminals "R", "S" and "T" to power source. Note that the specification of the electric wires must be above 8 sqr.mm of its cross section area. Power switch of the machine and power source should be with fuse and the machine ought to be grounded.

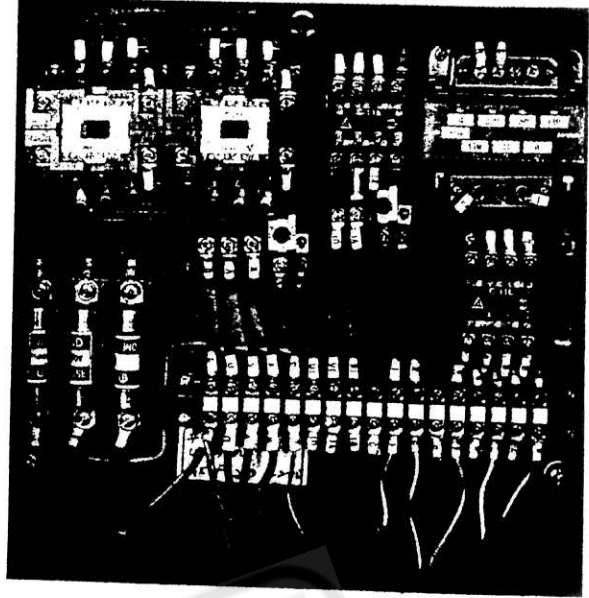

3-2 Electric Device

- 1) The electric pannel is equipped with cut-off device and solenoid contactor for avoiding from overloaded breakdown of motor.
- 2) Tumbler Rotation Switch connect with Micro Switch.
- 3) Foot brake is connectd with micro switch, braking prior to the manually starting. Whenever you release the foot brake, you need to re-operate Spindle Control Lever again to resume the operation of main spindle.
- 4) On top of the control box, there exist a "INTERMITTENT" button for intermittent operation of the spindle.

3-3 Important Notes

** Check the rotating direction of spindle after wiring:

1. Turn on the power switch.
2. Slightly push "INTERMITTENT" button.
3. Look at the rotating direction of Main Spindle from Tailstock.
4. If it is of anti-clockwise, you've got a right wiring.
5. If oppositely,exchange any of two wires among "R" "S" "T" terminals.

** If the power indicating lamp is on but you can not start the motor. Thus, it is over-loaded.



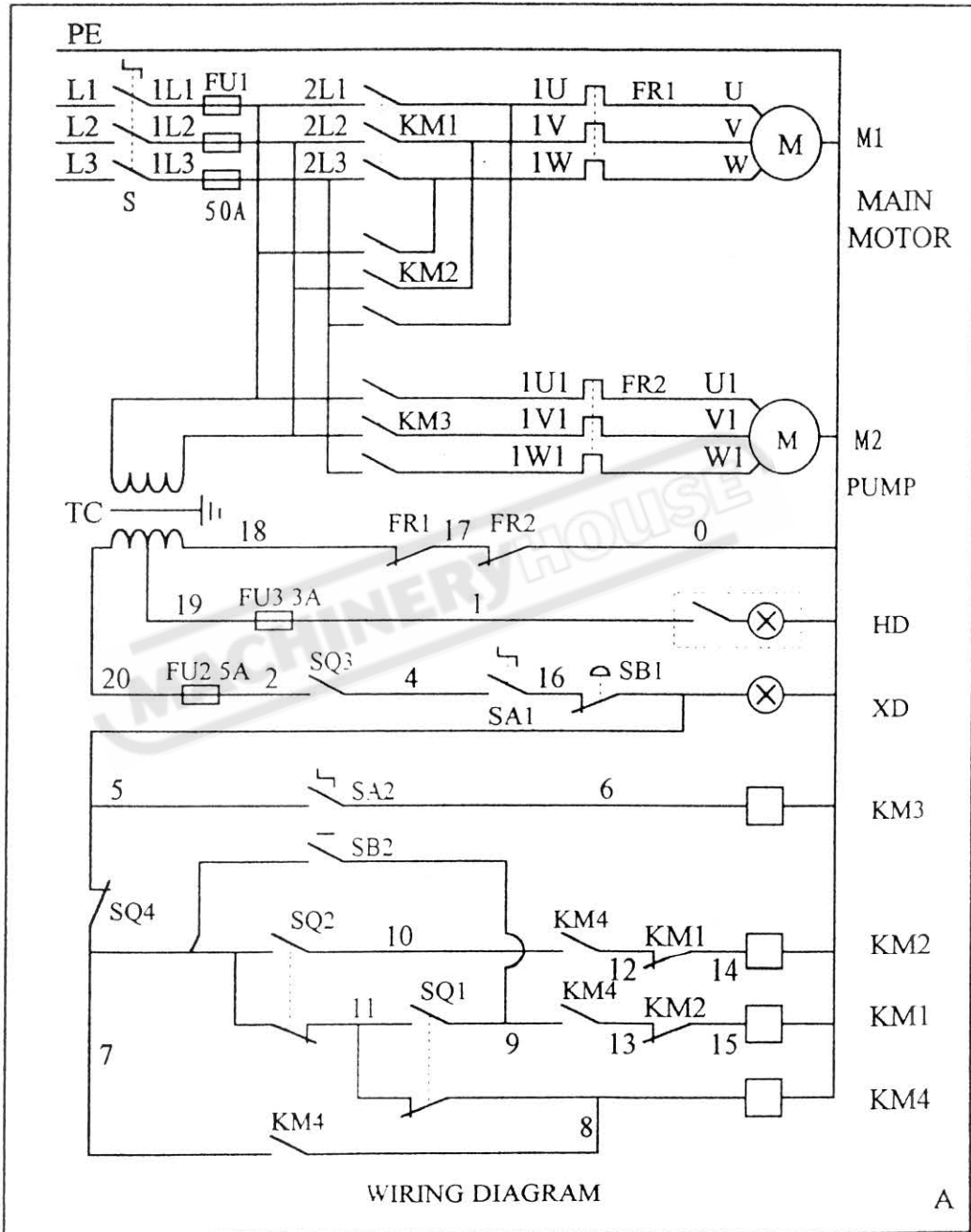

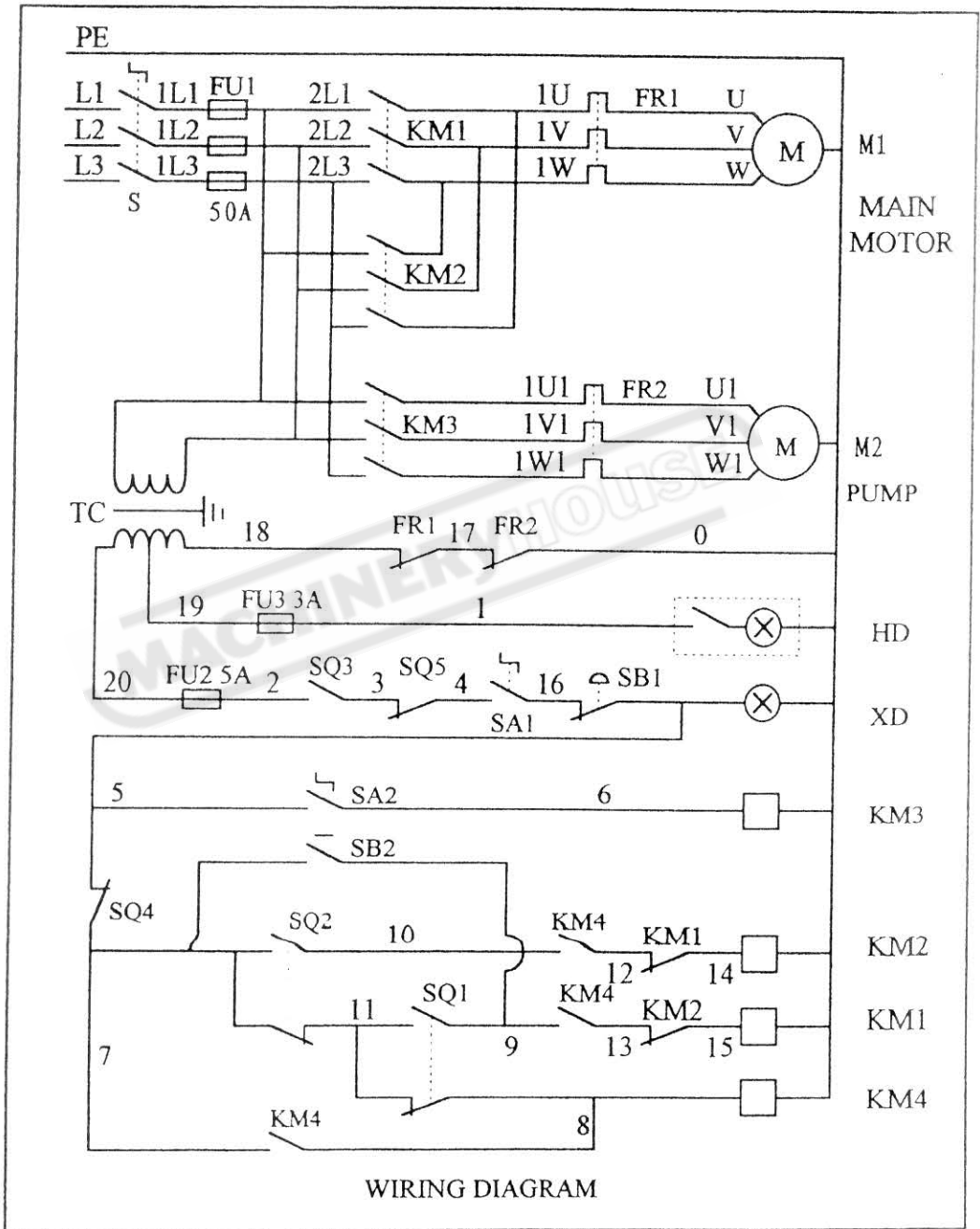









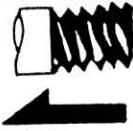
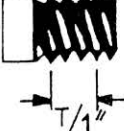



If it happens the current out of limit, the cut-off device will activate immediately. In this moment, please turn off the power then press slightly the recovery plate near cut-off device in the control box. It will work again. (electric circuit program as illustrated on next page).





4. Test Running

4-1 Operation Symbols

1		High speed revolution	11		Variable adjustment (pressure)(clock - wise-pressure in- creased; counterclock- wise pressure decreased)
2		Low speed revolution	12		Electrical control box
3		Forward revolution	13		Imperial threads
4		Neutral gear	14		Metric threads
5		Reverse revolution	15		Auto feeding rate per revolution
6		Light	16		Pump
7		Intermittent button	17		Power switch- ON
8		Cross feeding	18		Power switch- OFF
9		Longitudinal feeding	19		Oil inlet (hole)
10		Cone clutch	20		

4-2 Transmmission and Stop of Main Spindle

You can start test run when you follow the previous steps as illustrated by the Manual. Position the High/Low Speed Lever (2) in "L", Main Spindle Speed Change Lever (3) in left position, Forward/Reverse Lever (4) in the middle of "N" position. Turn Start Lever (11) Right and push down to rotate obversely the spinde;pull up. to rotate reversely. By using Spindle Control Lever to operate the machine in normal condition, use brake when it needs to stop in emergency. Naturally, in this case,

4-2

you need to push the Spindle Control Lever again in the middle position to re-start the Spindle.
Turn on Pump Switch (10) to start pump. Adjust Valve (33) is used for adjusting the required quantity of cooling water.

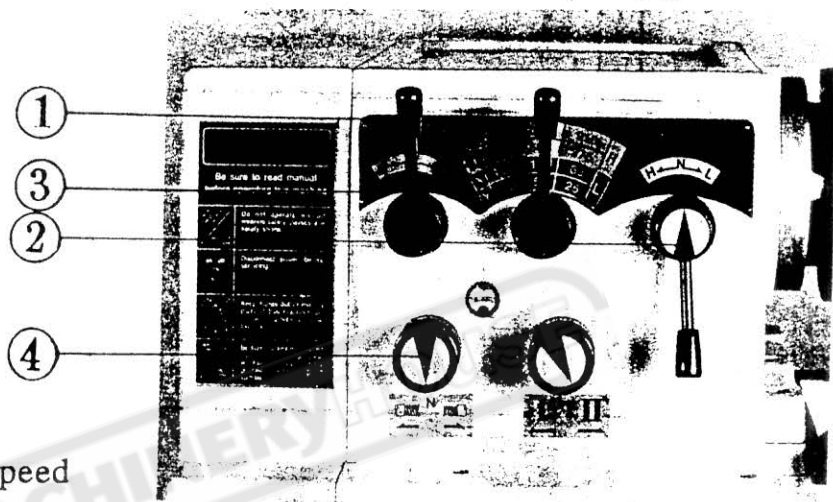

4-3 Selecting Main Spindle Speed

The speed of main spindle is consisted of 3 speed change lever,i.e. Speed Change Lever (1),High/Low Speed Lever(2) and Main spindle Speed Select Lever(3) to perform 12 speed change. When you shift High/Low Speed Lever (2) to the neutral position in between "H" and "L", you can rotate the Main Spindle only with you hands.

4-3

For the safely reason and not to injure the gear every speed change must operate in the time while motor stops. If the teeth of the gear can not be properly engaged, push "INTERMITTENT" button (9) then shift Speed Change Lever(1) (2) or (3) to change the rotating speed.

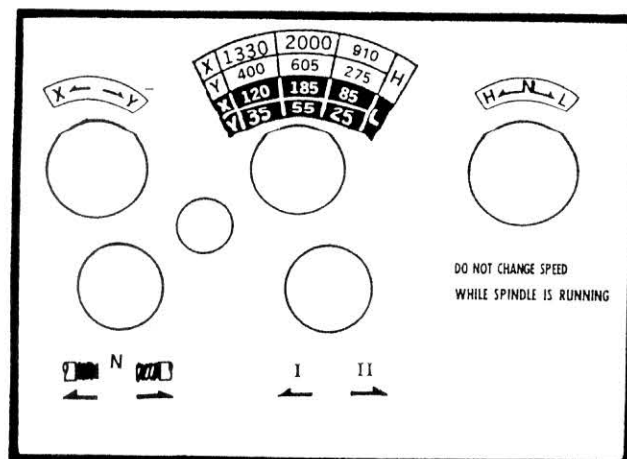

CAUTION:DO NOT CHANGE SPEED WHILE SPINDLE IS RUNNING.

BE SURE ALL GEARS ARE PROPERLY ENGAGED BEFORE STARTING.

4-4 "INTERMITTANT" Operation of Main Spindle

For the convenient way of changing Main Spindle Speed, confirming Feed Speed and Centering objects, the machine equipped with "INTERMITTANT" button (9) located in the right side of Gear Box. Push it down, Main Spindle will immediately rotate forward; and if to release the button, it stops. Note that the intermittant function can not rotate reversely.

illustration 4-4



4-5 The Importance and Methods of Spindle Levelling Adjustment

- 1) Switch on to make the Spindle turn while the Spindle is set up at 1330 r.p.m. By putting the palm of the left hand on the Headstock cover to feel its chatter. An unlevelling Spindle will lead to a lathe chatter. Move Levelling Block (either "A" or "B") left or right to adjust until your left hand feels the minimum chatter.
- 2) Afterwards, change the Spindle speed to 2000 r.p.m. or 900 r.p.m. and check the Levelling with the same way as we did at 1330 r.p.m. by adjusting the Levelling Block "A" or "B".

4-5

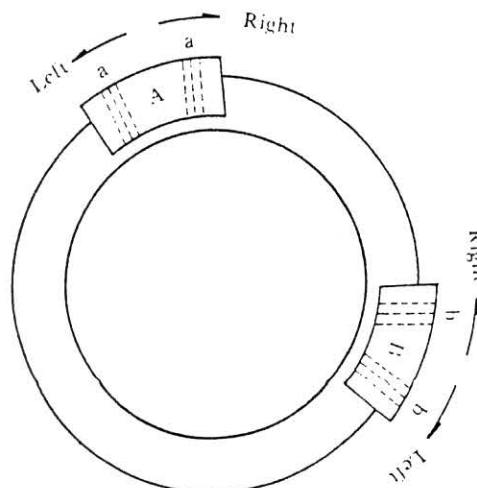

4-6 Transmission and Stop of Gear Box

Open the end side cover of Headstock, you will find a gear train transmit the power from Headstock to Gear Box. Shift Forward/Reverse Lever(4) to right side, it runs forward, or to left side, reversely, or it stops if you shift it to the middle position. Never change speed while machine is running.

4-7 Operation of Gear Box

1. Cutting Threads

A special designed Gear Box, you need not to use back gears to proceed threading. Please refer to gear box cutting feed table and shift to appropriate Thread Feed Select Lever (5) (6) (7) respectively then you may obtain required specification.

2. Auto Feed

The selection of Auto Feed should be coordinated with the cutting speed and feed speed. Please refer to cutting table and select proper feed speed and follow the instruction plate to shift thread Feed Select Lever (5) (6) (7).

4-8 Manual Operation

Firstly shift the Half Nut Engaged Lever(18) of Apron and Forward/Reverse Lever(4) to "N" position, then you can arbitrarily operate Longitudinal Apron Handwheel (13) Cross Slide Handle (14) and Compound Rest Handwheel(32).

It feeds 17mm per revolution of Apron Handwheel. The dials on Cross Slide and Compound Rest is graduated 0.02mm per division and feeds 4mm per revolution.

Release Tool Post Clamping Lever(36) and you can revolve the Tool Post anti-clockwise then fix it. In order to lock the Apron, only to screw up the Saddle Set Screw (20). If there is any backlash in between Cross Slide and Compound Rest, just to screw up the set screws on both ends of the sloping plate.

illustration 4-8

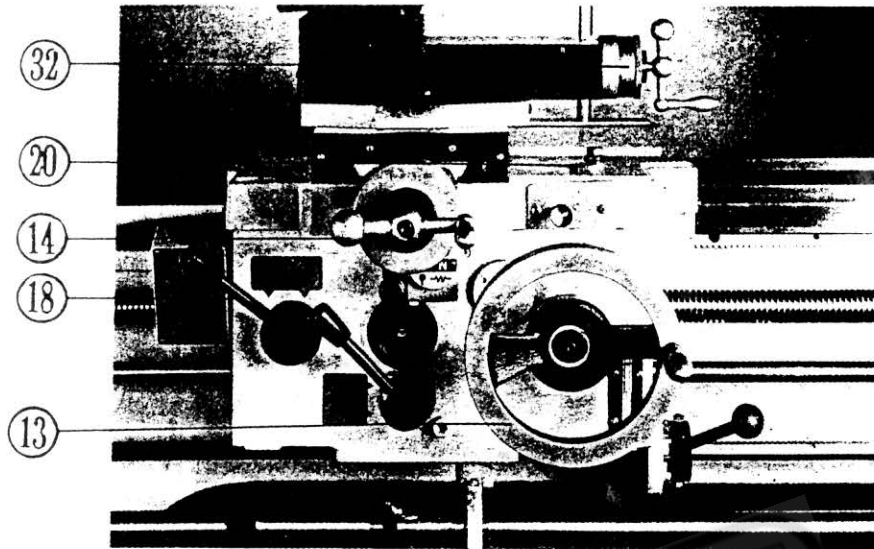

4-9 Auto Feed Operation

- 1) Shift Forward/Reverse Change Lever (4) on Headstock to decided the direction of feeding.
- 2) Select proper Feed Speed by shifting Gear Box Feed Change Lever.
- 3) Push down Half Nut Engaged Lever(18) to proceed threading.
- 4) Push down Longitudinal Feed Select Lever (19) when it needs to feed the tools crosswise.
- 5) Pull up Cross Feed Select Lever(19) when it needs to feed longitudinally.

4-10 Auto Feed Stop Operation

The machine is equipped with Auto Stop Feed in Apron. Screw up the screw on Eccentric Centering Ring (12) and settle in appropriate position. Note that the highest point of Eccentric Centering Ring have to be outward, and no mater it feed forward or backward,you can both set the Eccentric Centering Ring in required position. Test once before beginning to process in preventing unnecessary damage or danger.

illustration 4-10

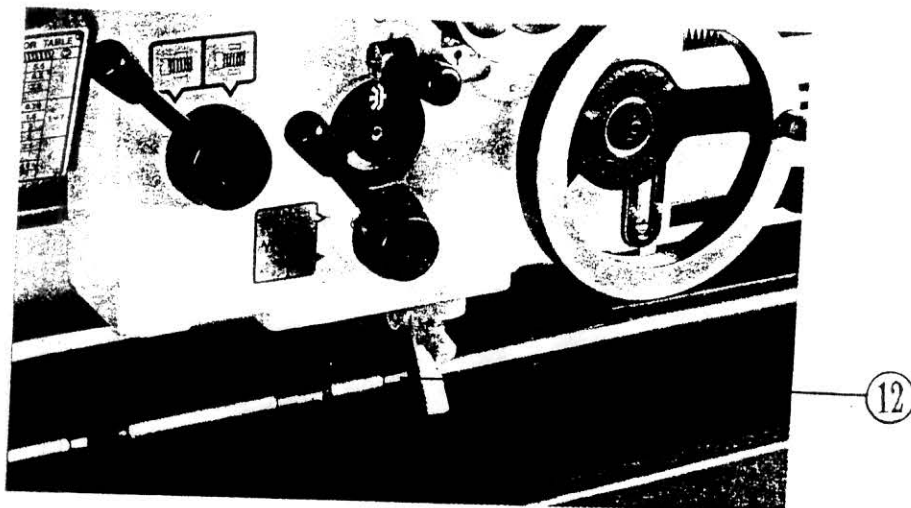

4-11 Four Position Auto Feed Stop Operation

If it requires to process the object to a certain length or object with steps, you may use this utility to complete a multi-section cutting.

- 1) Place Eccentric Centering Ring(12) to any require position, the highest point indicates outward. Then fix it. Now you can try to operate Auto Feed of Apron to make sure precisely position by adjusting Eccentric Centering Ring.
- 2) Secondly, turn Auto Centering Level to second point. Fix second Eccentric Centering Ring as per above method.
- 3) Same way to fix the third, the fourth.
- 4) While Apron is auto feeding forward, only the one Eccentric Centering Ring which with its highest point outward can touch the Auto Stop Centering (15) and stops Apron Feed, it will pass through all the rest of Eccentric Centering Rings and will not activate at all.

4-12 Tailstock Operation

- 1) Tailstock Handwheel Dial is divided 0.02mm per graduation. Tailstock Handwheel(28) revolves one cycle clockwise, the quill of Tailstock feeds 5mm. If revolves anti-clockwise, the quill runs backward; when it runs to the last the center will be automatically released.
- 2) By pushing the Tailstock Spindle Locking Lever(30) forward, you can steady the quill of Tailstock. If you wish to steady the Tailstock or the lathe bed you only need to push Tailstock Clamping Lever forward.

3) Tailstock Centering

Let loose of the Adjustment Screw (26) of Tailstock, then adjust the other side, tighten screws on both sides after adjustment.

4-12

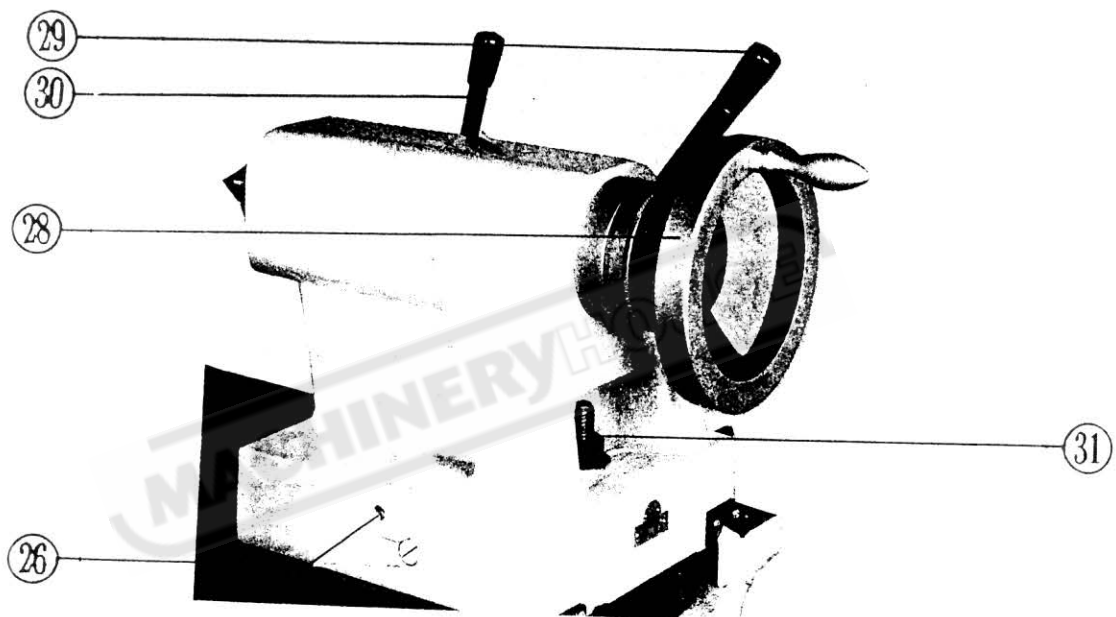

5. Cutting Threads

5-1 Leadscrew Drive

- 1) Forward Reverse shifting Lever (4) to right side. Leadscrew (24) reversely to left side. Leadscrew obversely to "N" position, thus. Leadscrew will not be rotated.



5-2 Cutting Thread

- 1) As soon as you decide to process which threads, Please position Thread Feed Select Lever (5) Thread Feed Change Lever (6) and 10 Steps Feed Change Disc. (7) in reference to the Thread Table.
- 2) Turn on the power, drive Leadscrew directly.
- 3) Push down Half Nut Engaged Lever(18) and start screw-cutting.

5-3 Thread Dial Indicator

- 1) To use Inch Leadscrew in processing Imperial Threads.



To proceed screw cutting in Imperial Threads, firstly you have to loose Half Nut then to match Half Nut as per instruction of Thread Dial indicator with no necessary to change Leadscrew. When you do this procedure of threading, lock the index disc on shaft (1) than take 16T worm gear so that you can process all Imperial threads; that is, you have to follow the indicating plate and not to loose Half Nut while cutting Metric threads.

INDICATOR TABLE		
		
4½ , 11½ 13½ , 23	16	2
5 , 7 9 , 11 3 , 19 26 , 27		4
OTHER EVEN NUMBER THREADS		8

2) To use Metric Leadscrew in processing Metric Threads

Use 11T worm gear to cut 2.75 and 5.5, but if you wish to repeatedly use Half Nut, it requires to steady it on a original fix scale. for instant,the original point shows scale 1 in index disc when next clutching you must be start it when it also indicates scale 1 for not to damage the threads. Same story, if it is on scale 5, you should also have it on scale 5 in next coming clutching.

Use 14T worm gear for cutting 0.5 and 0.75 and when you repeatedly use Half Nut you don't have to fit it on certain scale. It can be done without any damage on threads in any scales of index disc.

INDICATOR TABLE			
			
11T	2.75	5.5	1
13T	3.25	6.5	
14T	1.75	3.5	
	7		
	0.5	0.75	1~7
	1	1.5	
	2	3	
	4	6	
15T	1.25	2.5	
	5		
	2.25	4.5	
18T	6.75		

5-4 Thread and Feed Table

C6251A (Metric)

LEAD SCREW		P=6 mm											
CROSS FEED ROD		P=4 mm											
(V)		(W)											
	LEVER	1	2	3	4	5	6	7	8	9	10		
	II CFS	0.2			0.25			0.3			0.35		
	II CES	0.4	0.45		0.5	0.55		0.6	0.65		0.7		
	II CFU							0.75					
	I CFS	0.8	0.9					1.2			1.4		
	II CEU	1			1.25			1.5			1.75		
	I CFU	2	2.25		2.5	2.75		3	3.25		3.5		
	I CEU	4	4.5	4.75	5	5.5	5.75	6	6.5	6.75	7		
	I CDU	8	9	9.5	10	11	11.5	12	13	13.5	14		
		II ADR	64	72	76	80	88	92	96	104	108	112	
II AER		32	36	38	40	44	46	48	52	54	56		
II BER		16	18	19	20	22	23	24	26	27	28		
I AER		8	9	9 1/2	10	11	11 1/2	12	13	13 1/2	14		
I AFR		4	4 1/2	4 3/4	5	5 1/2	5 3/4	6	6 1/2	6 3/4	7		
I BFR		2	2 1/4	2 3/8	2 1/2	2 3/4	2 7/8	3	3 1/4	3 3/8	3 1/2		
		II CFS	0.1						0.15				
		II CES	0.2			0.25			0.3			0.35	
		I CFS	0.4	0.45		0.5	0.55		0.6	0.65		0.7	
		II CEU							0.75				
	I CES	0.8	0.9					1.2			1.4		
	I CFU	1			1.25			1.5			1.75		
	I CEU	2	2.25		2.5	2.75		3	3.25		3.5		
	I CDU	4	4.5	4.75	5	5.5	5.75	6	6.5	6.75	7		
		II AER	64	72	76	80	88	92	96	104	108	112	
		II BER	32	36	38	40	44	46	48	52	54	56	
I AER		16	18	19	20	22	23	24	26	27	28		
I AFR		8	9	9 1/2	10	11	11 1/2	12	13	13 1/2	14		
I BFR		4	4 1/2	4 3/4	5	5 1/2	5 3/4	6	6 1/2	6 3/4	7		
		LEVER	1	2	4	5	7	8	10				
		II CFT	0.059	0.066	0.073	0.081	0.088	0.096	0.103				
		II CET	0.118	0.132	0.147	0.162	0.176	0.191	0.206				
		I CFT	0.235	0.265	0.294	0.323	0.353	0.382	0.411				
		I CET	0.470	0.529	0.588	0.647	0.705	0.764	0.823				
	I CDT	0.940	1.058	1.176	1.293	1.411	1.528	1.646					
		II CFT	0.020	0.023	0.026	0.028	0.031	0.033	0.036				
		II CET	0.041	0.046	0.051	0.056	0.061	0.067	0.072				
I CFT		0.082	0.092	0.102	0.113	0.123	0.133	0.143					
I CET		0.164	0.184	0.205	0.225	0.246	0.266	0.287					
I CDT		0.327	0.368	0.409	0.450	0.491	0.532	0.573					

C6251A (Inch)

**LEAD SCREW
CROSS FEED ROD**

**4. T. P. I
10. T. P. I**

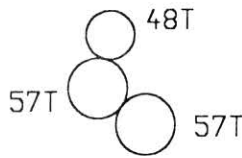

(V)

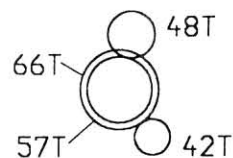

(W)

	LEVER	1	2	3	4	5	6	7	8	9	10	
<p>(V)</p>	II CFS	0.2			0.25			0.3			0.35	
	II CES	0.4	0.45		0.5	0.55		0.6	0.65		0.7	
	II CFU							0.75				
	I CFS	0.8	0.9					1.2			1.4	
	II CEU	1			1.25			1.5			1.75	
	I CFU	2	2.25		2.5	2.75		3	3.25		3.5	
	I CEU	4	4.5	4.75	5	5.5	5.75	6	6.5	6.75	7	
	I CDU	8	9	9.5	10	11	11.5	12	13	13.5	14	
	<p>(V)</p>	II ADR	64	72	76	80	88	92	96	104	108	112
		II AER	32	36	38	40	44	46	48	52	54	56
II BER		16	18	19	20	22	23	24	26	27	28	
I AER		8	9	9 1/2	10	11	11 1/2	12	13	13 1/2	14	
I AFR		4	4 1/2	4 3/4	5	5 1/2	5 3/4	6	6 1/2	6 3/4	7	
I BFR		2	2 1/4	2 3/8	2 1/2	2 3/4	2 7/8	3	3 1/4	3 3/8	3 1/2	
<p>(W)</p>		II CFS	0.1						0.15			
		II CES	0.2			0.25			0.3			0.35
		I CFS	0.4	0.45		0.5	0.55		0.6	0.65		0.7
		II CEU							0.75			
	I CES	0.8	0.9					1.2			1.4	
	I CFU	1			1.25			1.5			1.75	
	I CEU	2	2.25		2.5	2.75		3	3.25		3.5	
	I CDU	4	4.5	4.75	5	5.5	5.75	6	6.5	6.75	7	
	<p>(W)</p>	II AER	64	72	76	80	88	92	96	104	108	112
		II BER	32	36	38	40	44	46	48	52	54	56
I AER		16	18	19	20	22	23	24	26	27	28	
I AFR		8	9	9 1/2	10	11	11 1/2	12	13	13 1/2	14	
I BFR		4	4 1/2	4 3/4	5	5 1/2	5 3/4	6	6 1/2	6 3/4	7	
<p>(V)</p>		LEVER	1	2	4	5	7	8	10			
	II CFT	0.0022	0.0025	0.0027	0.0030	0.0033	0.0036	0.0038				
	II CET	0.0044	0.0049	0.0055	0.0060	0.0066	0.0071	0.0077				
	I CFT	0.0087	0.0098	0.0109	0.0120	0.0131	0.0142	0.0153				
	I CET	0.0175	0.0197	0.0219	0.0241	0.0262	0.0284	0.0306				
	I CDT	0.0350	0.0394	0.0437	0.0481	0.0525	0.0569	0.0612				
	<p>(V)</p>	II CFT	0.00048	0.00054	0.00060	0.00066	0.00073	0.00079	0.00085			
		II CET	0.00097	0.00109	0.00121	0.00133	0.00145	0.00157	0.00169			
		I CFT	0.00193	0.00218	0.00242	0.00266	0.00290	0.00314	0.00338			
		I CET	0.00387	0.00435	0.00484	0.00532	0.00580	0.00629	0.00677			
<p>(V)</p>		I CDT	0.00774	0.00870	0.00967	0.01064	0.01160	0.01257	0.01354			

C6256A (Metric)

LEAD SCREW

P=6 mm

CROSS FEED ROD

P=4 mm

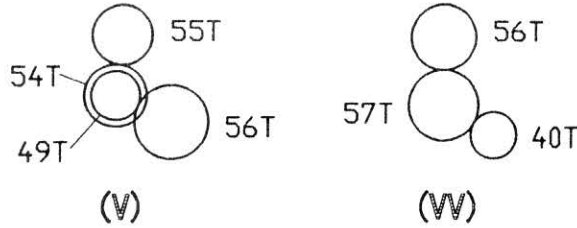

	LEVER	1	2	3	4	5	6	7	8	9	10	
<p>(V)</p>	II CFS	0.2			0.25			0.3			0.35	
	II CES	0.4	0.45		0.5	0.55		0.6	0.65		0.7	
	II CFU							0.75				
	I CFS	0.8	0.9					1.2			1.4	
	II CEU	1			1.25			1.5			1.75	
	I CFU	2	2.25		2.5	2.75		3	3.25		3.5	
	I CEU	4	4.5	4.75	5	5.5	5.75	6	6.5	6.75	7	
	I CDU	8	9	9.5	10	11	11.5	12	13	13.5	14	
	<p>(V)</p>	II ADR	64	72	76	80	88	92	96	104	108	112
		II AER	32	36	38	40	44	46	48	52	54	56
II BER		16	18	19	20	22	23	24	26	27	28	
I AER		8	9	9 1/2	10	11	11 1/2	12	13	13 1/2	14	
I AFR		4	4 1/2	4 3/4	5	5 1/2	5 3/4	6	6 1/2	6 3/4	7	
I BFR		2	2 1/4	2 3/8	2 1/2	2 3/4	2 7/8	3	3 1/4	3 3/8	3 1/2	
<p>(W)</p>		II CFS	0.1						0.15			
		II CES	0.2			0.25			0.3			0.35
		I CFS	0.4	0.45		0.5	0.55		0.6	0.65		0.7
		II CEU							0.75			
	I CES	0.8	0.9					1.2			1.4	
	I CFU	1			1.25			1.5			1.75	
	I CEU	2	2.25		2.5	2.75		3	3.25		3.5	
	I CDU	4	4.5	4.75	5	5.5	5.75	6	6.5	6.75	7	
	<p>(W)</p>	II AER	64	72	76	80	88	92	96	104	108	112
		II BER	32	36	38	40	44	46	48	52	54	56
I AER		16	18	19	20	22	23	24	26	27	28	
I AFR		8	9	9 1/2	10	11	11 1/2	12	13	13 1/2	14	
I BFR		4	4 1/2	4 3/4	5	5 1/2	5 3/4	6	6 1/2	6 3/4	7	
<p>(V)</p>		LEVER	1	2	4	5	7	8	10			
		II CFT	0.059	0.066	0.073	0.081	0.088	0.096	0.103			
		II CET	0.118	0.132	0.147	0.162	0.176	0.191	0.206			
		I CFT	0.235	0.265	0.294	0.323	0.353	0.382	0.411			
		I CET	0.470	0.529	0.588	0.647	0.705	0.764	0.823			
	I CDT	0.940	1.058	1.176	1.293	1.411	1.528	1.646				
	II CFT	0.020	0.023	0.026	0.028	0.031	0.033	0.036				
	II CET	0.041	0.046	0.051	0.056	0.061	0.067	0.072				
	I CFT	0.082	0.092	0.102	0.113	0.123	0.133	0.143				
	I CET	0.164	0.184	0.205	0.225	0.246	0.266	0.287				
<p>(V)</p>	I CDT	0.327	0.368	0.409	0.450	0.491	0.532	0.573				

C6256A (Inch)

LEAD SCREW
CROSS FEED ROD

4. T. P. I
10. T. P. I

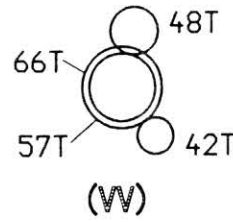
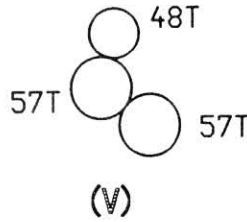

 mm	LEVER	1	2	3	4	5	6	7	8	9	10	
	II CFS	0.2			0.25			0.3			0.35	
	II CES	0.4	0.45		0.5	0.55		0.6	0.65		0.7	
	II CFU							0.75				
	I CFS	0.8	0.9					1.2			1.4	
	II CEU	1			1.25			1.5			1.75	
	I CFU	2	2.25		2.5	2.75		3	3.25		3.5	
	I CEU	4	4.5	4.75	5	5.5	5.75	6	6.5	6.75	7	
	I CDU	8	9	9.5	10	11	11.5	12	13	13.5	14	
	 T/P	II ADR	64	72	76	80	88	92	96	104	108	112
II AER		32	36	38	40	44	46	48	52	54	56	
II BER		16	18	19	20	22	23	24	26	27	28	
I AER		8	9	9 1/2	10	11	11 1/2	12	13	13 1/2	14	
I AFR		4	4 1/2	4 3/4	5	5 1/2	5 3/4	6	6 1/2	6 3/4	7	
I BFR		2	2 1/4	2 3/8	2 1/2	2 3/4	2 7/8	3	3 1/4	3 3/8	3 1/2	
 MP		II CFS	0.1						0.15			
		II CES	0.2			0.25			0.3			0.35
		I CFS	0.4	0.45		0.5	0.55		0.6	0.65		0.7
		II CEU							0.75			
	I CES	0.8	0.9					1.2			1.4	
	I CFU	1			1.25			1.5			1.75	
	I CEU	2	2.25		2.5	2.75		3	3.25		3.5	
	I CDU	4	4.5	4.75	5	5.5	5.75	6	6.5	6.75	7	
	 DP	II AER	64	72	76	80	88	92	96	104	108	112
		II BER	32	36	38	40	44	46	48	52	54	56
I AER		16	18	19	20	22	23	24	26	27	28	
I AFR		8	9	9 1/2	10	11	11 1/2	12	13	13 1/2	14	
I BFR		4	4 1/2	4 3/4	5	5 1/2	5 3/4	6	6 1/2	6 3/4	7	
 mm / °		LEVER	1	2	4	5	7	8	10			
		II CFT	0.0022	0.0025	0.0027	0.0030	0.0033	0.0036	0.0038			
		II CET	0.0044	0.0049	0.0055	0.0060	0.0066	0.0071	0.0077			
		I CFT	0.0087	0.0098	0.0109	0.0120	0.0131	0.0142	0.0153			
		I CET	0.0175	0.0197	0.0219	0.0241	0.0262	0.0284	0.0306			
	I CDT	0.0350	0.0394	0.0437	0.0481	0.0525	0.0569	0.0612				
	 mm / °	II CFT	0.00048	0.00054	0.00060	0.00066	0.00073	0.00079	0.00085			
		II CET	0.00097	0.00109	0.00121	0.00133	0.00145	0.00157	0.00169			
		I CFT	0.00193	0.00218	0.00242	0.00266	0.00290	0.00314	0.00338			
		I CET	0.00387	0.00435	0.00484	0.00532	0.00580	0.00629	0.00677			
I CDT		0.00774	0.00870	0.00967	0.01064	0.01160	0.01257	0.01354				

6. Lubrication

6-1 Lubrication in Headstock

A oil-splash feed is utilized in the lubricating system of Headstock. On top of the Headstock there are grooves surrounded providing lubricant flow into the spindle bearing along the groove, then finally flow down on the bottom of the box. When supplying the lubricant, remove the cap of oil plug beside Headstock, fill from the hole up to the bottom level of front oil sightglass. To drain the waste oil away, a drainer hole located in the right side downward of the Headstock.

Please take good care of checking whether the Headstock have been filled up with lubricant or not when you purchase the machine. If negative, use as show in the figure (6-4) Lubricating Oil. We request you to change the lubricant at first month and then do once every two months so to assure the gears are working in the best conditions.

6-2 Lubricating in Gear Box and Apron

- 1) Gear Box is oil-bath lubricated to insure the lifetime of gears and bearing. It is recommended the lubricant to be changed every six months.
- 2) Apron is also oil-bathed. If the oil quantity in Apron is lower than center level of oil sightglass, then it is time to add up some more oil to standard level.

6-3 Useful Reference Lubricating Table for other Mechanism

NO	Location	How	How Many	For how long to fill-up	Oil exchange time
1	Headstock	Remove the screws of filler hole on left side up	L	once a month	one month, then every two months
2	Gear Box	Open top cover remove the screws of filler hole	L	//	every half year
3	Apron	Remove the screws of filler hole	L	everyday	
4	Compound Rest	by oilcan	approp.	//	
5	Auto Feed Lever	by oilcan	approp.	//	
6	Tailstock	by oilcan	approp.	//	
7	Leadscrew	by oilcan	approp.	//	
8	Bracket of Three Rods	Remove the screw of filler hole	approp.	//	
9	Bedway	Press the manual oil pump	approp.	//	

6-3 Add oil once a day

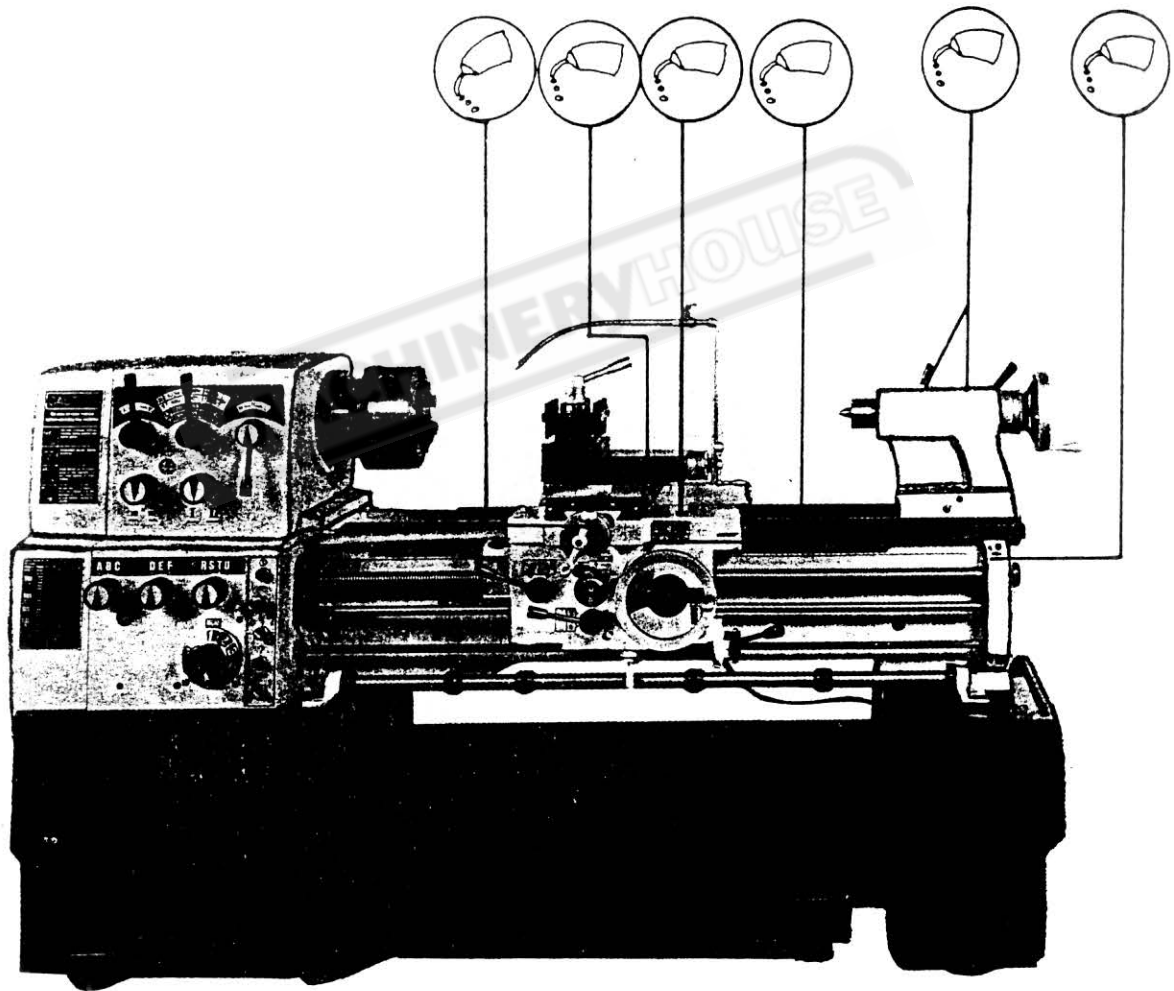



6-4 Lubrication Location

(A) Filler hole

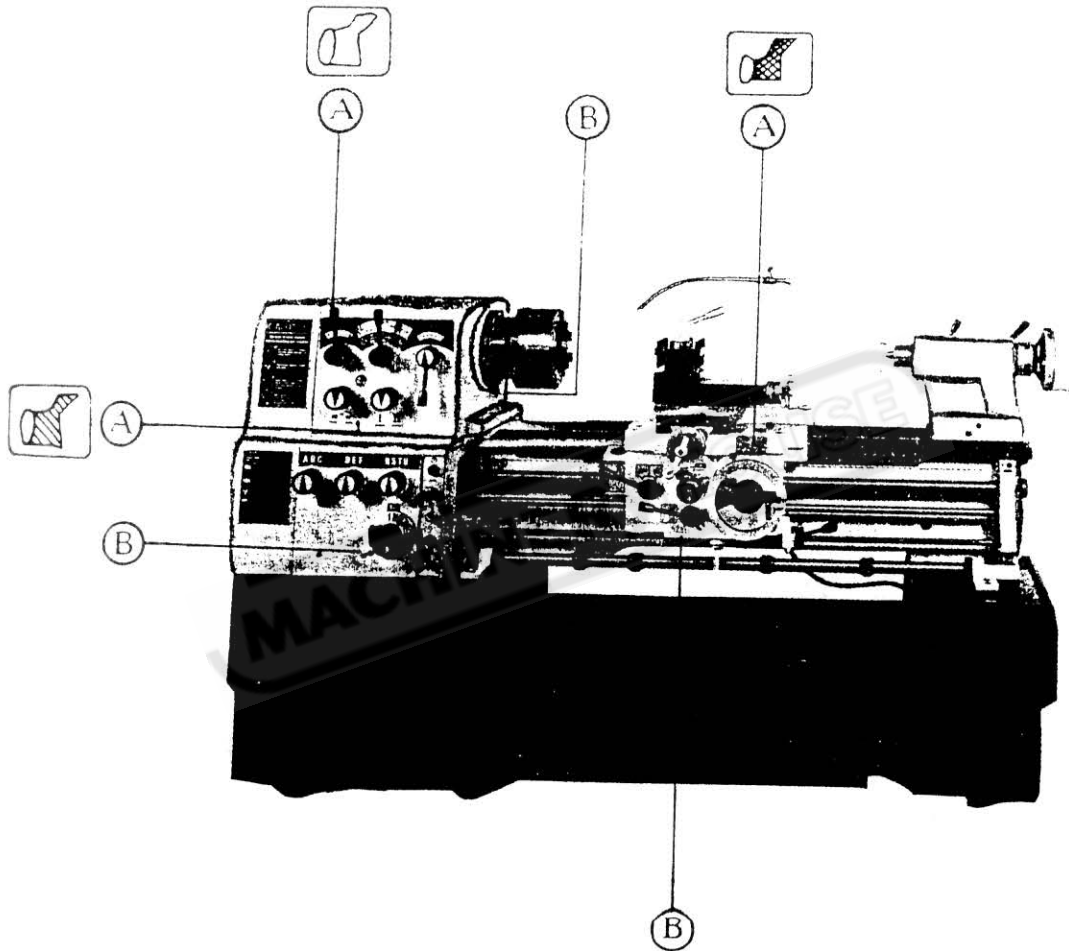
(B) Drainer hole



	Mobil	BP	Castrol	CC	ESSO	Shell	TEXACD
	DTE OIL HEAVY MEDIUM	ENERGOL HLP 68 (ISO)	HYPIN AWS68	R.W.L.C.	NUTO H68	TELLUS 68	RANDO HD68
	VACTRA EXTRA HEAVY	ENERAOL HP 100 OSON	ALPHA ZH 220	WLP	NURAY 100	VITARA 220	REGAL R10 220
	WAYOIL ISO UG68						

7. Maintenance & Servicing

For a better acknowledgement to this lathe, either in operation or some simple way of trouble-shooting or servicing, to bring the machine to the utmost function, we are now stating some important points as below:

7-1 Headstock

- 1) Prevent from oil leakage from top cover of Headstock:

Before covering the top cover of Headstock, whenever it is removed, please wipe to clean the contact surface and apply some grease on it. Make sure it is tightly secured by set screws.

- 2) Prevent from blocking up the oil circuit:

The leakage of front Headstock cover mostly caused by over-filling the oil or a block-up of oil circuit. In this moment, remove the Headstock cover first, then blow the air jet into two oil circuit hole, which is on up side and down side of front Spindle bearing, in the same time to rotate the Spindle and it will work again.

- 3) Adjustment on Spindle Bearing:

The front and intermediate section of Spindle roller bearing. For high accuracy and to meet the request of operation function, you may be asked to adjust the appropriate pressure on bearing. After a long period of operation, nut "G" probably will get loose and result the "wave trace" on cutting surface.

You need to adjust it at this moment. Use a hexagon socket wrench to remove the set screw and install back with the fixing nut again properly.

Only an appropriate pressure is enough.

illustration 7-1-3

Never have it too tight as it will lead to the bearing to over-heated or damage the rolling surface of bearing and lessen its dynamics. Make sure to fix the set screw completely after adjustment as illustrated.

Ⓒ

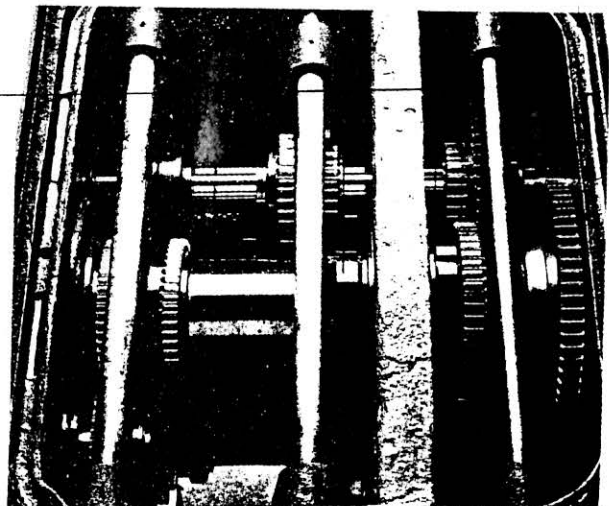

7-2 Apron & Saddle

1) Filler hole location of Apron:

On the right platform of Saddle. The filler hole has a oil plug indicates "OIL".

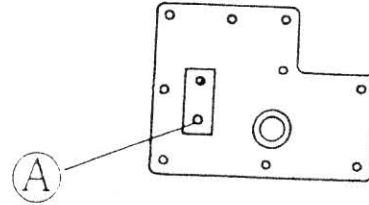

2) Drainer Hole location of Apron:

On the bottom cover of Apron, as illustrated left, position "A" (also can be seen in front side of Apron downward)

3) Model No. of Apron lubricant & change period

Model No. is way oil. ISO UG 68. suggestion changing period is every half year.

4) Adjustment for the loosely Half Nut Engaged Lever:

After long period of operation, the Half Nut Engaged Lever will get loose, please adjust as per following steps:

a. Remove Thread Dial Indicator, there are four adjustment screws can be seen.

b. Adjust those four screws to proper pressure as soon as to push the lever.

c. Install Thread Dial Indicator back.

5) Feed load adjustment (cross feed & longitudinal feed):

There is a conical clutch "D" in the middle of Apron which is a overload protector device. The capacity of safety load is about 12 kgs. Appropriate load can be adjusted by a hexagon socket screw in the middle of Apron.

Turn clockwise to increase

load; anti-clockwise to de-

crease. A proper load ca-

capacity can be tested by

pressing handwheel handle

while auto feed operates

to see if it will automa-

tically cut-off when load

is over 12 kgs.

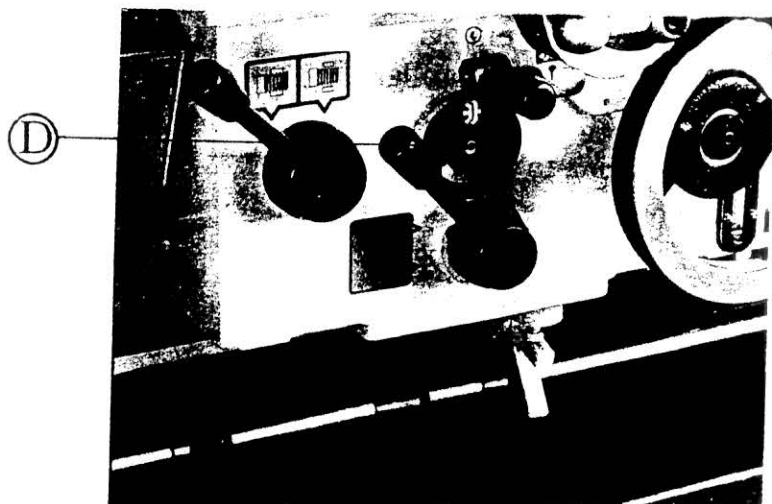

7-2-5

7-3 Gear Box

1) Filler hole location of Gear Box:

Under the top cover of gear box, remove the top cover there is an oil plug indicates "OIL" where filler hole is in. as per illustration "A".

2) Drainer hole location of Gear Box:

On the left side of the ten-step speed change disc downward. The drainer hole is in the screws with hexagon socket nut as illustrated "B" where an arrow point to.

3) Oil brand and oil exchange time:

We suggest as show in The figure 6-4 and please change it every half year.

7-3



7-4 Adjustment of Tailstock Centering

- 1) To adjust the accuracy of Tailstock, get loose two hexagon socket screws which connect the Tailstock body and Bottom Plate. adjustment to be done depends on what you expect it to which direction; if you need it to be inclined front, you must let loose the adjustment screws then correct it to required accuracy minutely, then install the hexagon socket screws and the adjustment screws. Never have it too tight or the Clamping Lever will be come heavier. as per illustrated "A".
- 2) If you feel the Release Handwheel is still too heavy although the Tailstock quill has been fixed. This is because the Clamping Block can not be released freely. You have to push forward the Clamping lever a bit and it will recover in good order again.

illustration 7-4

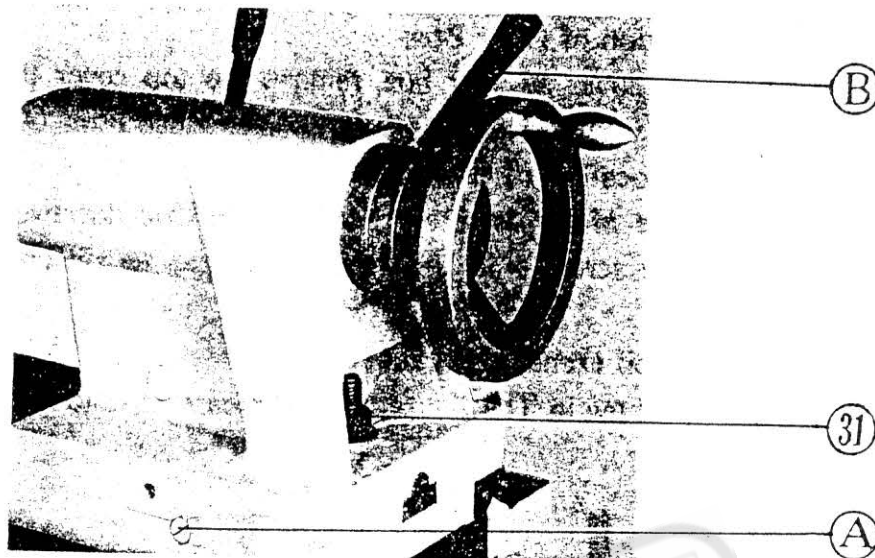

7-5 Belt Tension Adjustment

After long period of working, belts will get slacked, so you need to adjust it for some times. It is as:

- 1) Open the cover on rear left side of the lathe.
- 2) Release adjustment Nut "A", lower the motor to proper height and bring the belt to certain tension.
- 3) Install the Nut tightly.

7-5

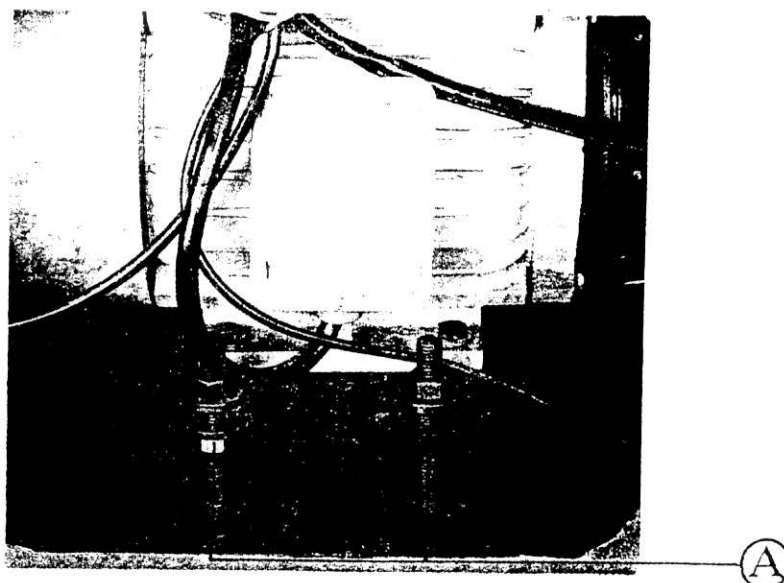

7-6 Foot Brake Belt Adjustment

A brake pad fading may be caused by the slack of the brake belt. Adjust Nut "H" on the brake belt. Open the side rear cover, remove the top nut, push the bottom nut to the appropriate position, then install two nuts to complete the adjustment. Install the side rear cover.

illustration 7-6

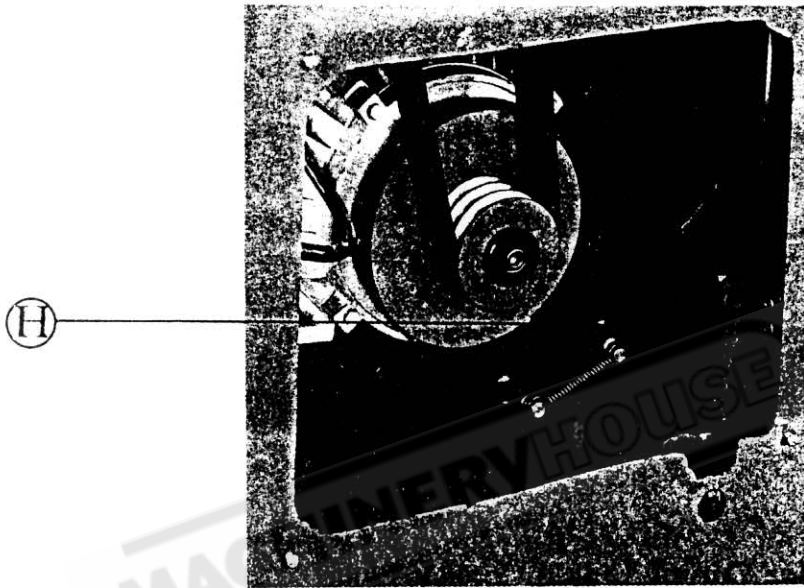

7-7 Brake and Micro Switch Adjustment

The foot brake is linked to the micro switch. It needs to maintain a backlash of 3-5 mm from the brake cam to the touching head of the micro switch. Always disconnect the power to the brake machine or it will cause the fading of the brake pad. After stepping the foot brake, you need to reoperate the spindle control lever to make the spindle revolute again.

illustration 7-7

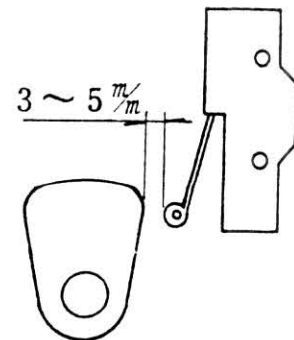

7-8 Adjustment to the Backlash of Leadscrew

When it happens to have some pile-up threads during processing, it is caused by the backlash on the leadscrew. Adjust the packing nut appropriately on the rear side of the leadscrew. Open the cover on the rear side of the leadscrew bracket, turn nut "A" very tight with no backlash left behind. (To check the result by pushing down the Nut Handle, turn the Apron Handwheel to rotate, clasp the contact point between the Gear Box and Leadscrew. Make sure there is no backlash created).

Install "A" nut and side cover.
illustration 7-8

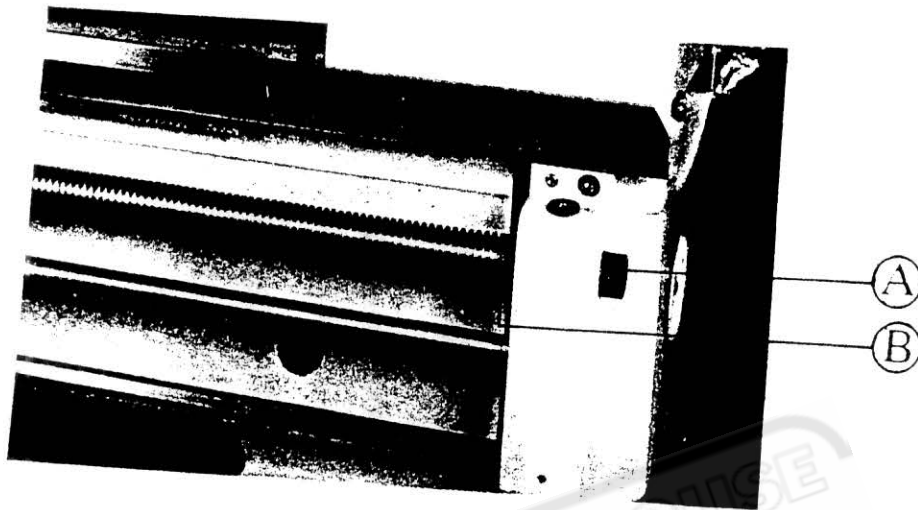

7-9 Maintenance for Cutting Liquid Coolant Pump

If there is no cutting liquid flow out when you start the motor switch, you have to check whether motor has activated or not, secondly to check whether the cutting liquid in tank is over the level, if not, needs to add more liquid. While re-starting the pump if you still can not see any liquid were pumped out, it must be some block-up in pump or leakage, and it has to be taken apart for servicing or cleaning.

8. CHUCKS AND CHUCK MOUNTING

When fitting chucks or faceplates, first ensure that spindle and chuck tapers are perfectly clean and that all cams lock in the correct positions; see Fig. 3. It may be necessary when mounting a new chuck to re-set the camlock studs (A). To do this, remove the cap-head locking screws (B) and set each stud so that the scribed ring (C) is flush with the rear face of the chuck with the slot lining up with the locking screw hole.

Now mount the chuck or faceplate on the spindle nose and tighten the six cams in turn. When fully tightened, the cam lock line on each cam should be between the two V marks on the spindle nose.

If any of the cams do not tighten fully within these limit marks, remove the chuck or faceplate and re-adjust the stud as indicated in the illustration. Fit and tighten the locking screw (B) at each stud before remounting the chuck for work. A reference mark should be made on each correctly fitted chuck or faceplate to coincide with the reference mark scribed on the spindle nose.

This will assist subsequent remounting. Do not interchange chucks or face plates between lathes without checking for correct cam locking.

FIG 3

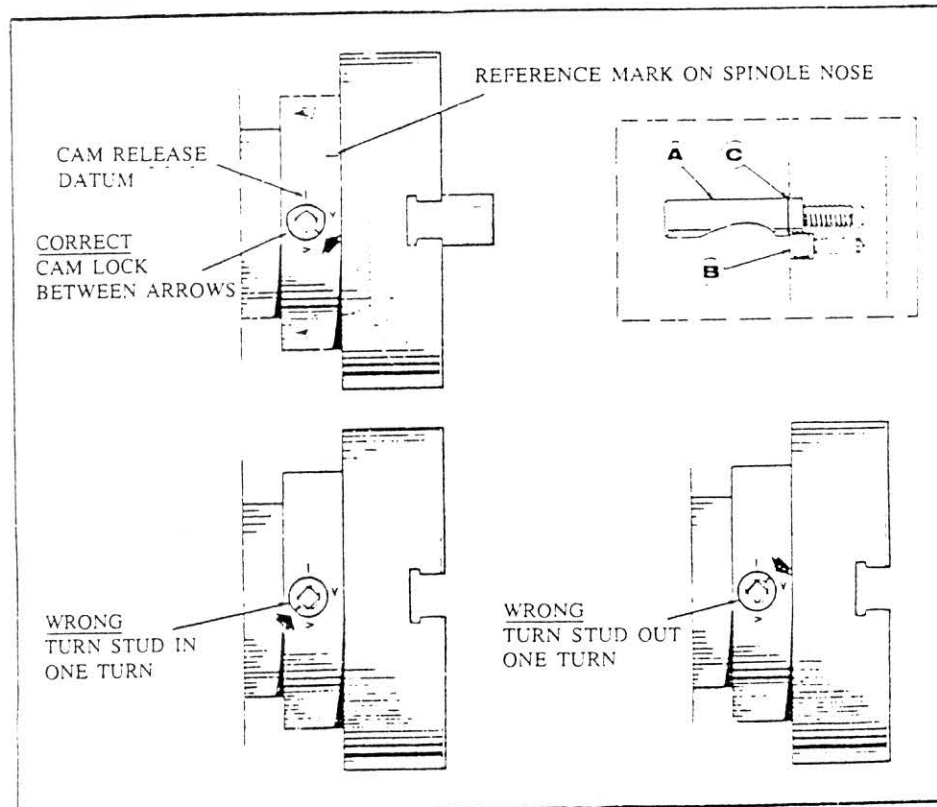

9. PREVENTIVE MAINTENANCE

1. DAILY INSPECTION:

In principle the daily inspection of lathe is carried out on basis of each shift. The inspection work according to the following item 1-1.

1-1 Check before starting the motor.

- 1) Clean-up of machine: Dust, chips and other articles should be removed from sliding surface of machine to make the rotating or sliding parts performing easy and smoothly. All other static parts be often also cleaned to avoid the corrosion.
- 2) Greasing and oiling: Regular oiling should be done every day (see lubrication plan sheet) to keep the machine properly lubricated.
- 3) Check all the running parts not too tight, or loose. Bearings of headstock, longitudinal and cross feed, tool holders etc would be examined and adjusted by hand to proper fitness.
- 4) Check the sensitivity & reliability of all manual control levers:
To try the speed change rate function of headstock feeds and apron in gear box and inspect their starting, stopping and forward & reverse action whether they are sensitive and reliable or not.
- 5) Fixture and fig of headstock, tailstock and tool holder Tight clamping between tailstock and bed surface, close running fit of spindle in tailstock, clamp bolts of tool holder, and figs on headstock.

1-2 Check after starting the motor.

- 1) To check electrical control system:
Try to put "on" and "off" button and examine the sensitiveness of starting, stopping and pilot lamp strictly.
- 2) The sensitivity and reliability of mechanical control device:
Control levers for forward and reverse main spindle, automatic feeds and threads change should be sensitive and reliable. Automatic control devices for longitudinal and cross feed, gear change threads change, carriage, and spindle direction change should be accurate also.
- 3) Limitation of noise and vibration:
When starting max. speed of headstock spindle on no loading basis, check the noise and vibration whether They are over speci-

fied limit or not.

4) Coolant system:

Check the quantity of coolant oil and start the oil pump for inspecting its function and leakage.

5) Lubricating system.

Examine all Lubricating system carefully and ensure all flowing line without obstacles.

1-3 Caution during operation:

1) Temperature of bearings.

Touch the main bearing by hand and feel the temperature is normally or not.

2) Temperature of motor:

To feel the temperature of motor bearing at the case of full load.

3) Noise and vibration:

If you find the noise and vibration of the machine are abnormal or irregular. Stop the machine immediately for inspection and adjustment.

4) Quality of products:

If you discover the quality of products is out of limit, stop the machine at once for finding the causes of defects.

5) Safety affairs:

a. Must stop operation when you leave the machine.

b. When changing main spindle speed or feeding speed stop running first.

c. All tools and products are strictly not allowed to be left on sliding surface of bed.

1-4 Check after operation:

1) Cleaning and collection of all tools:

All tools should be kept clean first then put back to original position (tool cabinet).

2) Proper position of tailstock, carriage, & tool holder:

Tailstock, carriage & tool holder should be placed to proper position:

3) Clean-up of machine:

All of the oily matters, chips etc, on the machine should be removed completely and put a thin lubricating oil on the sliding

surface of machine to prevent the corrosion.

2.WEEKLY INSPECTION:

- 1) Lubricating system:
Clean-up the whole lubricating system and replenish with fresh lubricating oil.
- 2) Cooling system:
Clean-up the whole cooling system and replenish with new cooling oil.
- 3) Transmission system:
Check the damage of rubber V-belt and readjust the tensile strength of V-belt.

3.MONTHLY INSPECTION:

- 1) Dismantle and clean all the dust, chips and foreign matter from moving parts.
- 2) Electrical System:
Carefully examine the connection of all electrical wires, terminals and switches, which occasionally have been damaged by chips or others.

4.SEMI-YEARLY INSPECTION

- 1) Change oil in gear box:
Remove the used oil from gear box of headstock, feed and replenish with fresh oil.
- 2) Check the wear and tear of all gears and packings:
Inspect the damage of all gears in various box.spindle and bearings, and packings. Repair or replace it if necessary.
- 3) Check the clearance fit of complicated feed mechanism:
Check the clearance fit between feeding screw lever and nut and main screw spindle and nut whether they are right or not.
- 4) The stability of machine body:
Tighten up the foundation bolts of machine body to the ground and make the body stable.

5.YEARLY INSPECTION:

- 1) Positioning and leveling:

According to the inspection regulation, recheck the positioning and leveling after one year service.

2) Inspection for accuracy:

According to the regulation, Inspection work for accuracy should be rechecked, If the accuracy is over specified limit, the adjustment or alingment will be done accordingly.

3) Bearing inspection:

Reexamine the insulating materials and clearance fit & lubrication of all bearings.

4) Inspection for appearance:

a.If paint is peeled off. repaint it with the same color.

b.Check the exposed parts whether they have been damaged, corroded, or deformed, repair or replace them if necessary.

MACHINERYHOUSE

10.TROUBLE SHOOTING

PORTION OF MACHINE

TROUBLE	PROBABLE CAUSES	REMEDY
Overheat of headstock bearing	<ol style="list-style-type: none"> 1.Oil level in headstock is too low or too high. 2.Quality and viscosity of oil is wrong. 3.Oil is too dirty. 4.Oil hole in bearing obstructed by dirt. 5.Bearing obstructed by dirt. 6.Badly worn bearing. 7.Bearing in its case is not in proper position. 8.Bent or sprung main spindle. 9.Too much end thrust. 	<p>Check the oil level and replenish or discharge the oil to the proper level.</p> <p>Replace the oil with recommended one.</p> <p>Replace oil.</p> <p>Remove the dirt from the oil hole</p> <p>Clean the bearing and renew oil.</p> <p>Replace bearing.</p> <p>Dismantle and reassemble it.</p> <p>Replace main spindle.</p> <p>Adjust thrust nut.</p>
Oil leakage from gear box.	<ol style="list-style-type: none"> 10.Plug of drain not tightly. 11.Headstock cracking. 12.Leakage from overflow headstock cover. 13.Leakage from overflow spindle bearing house. 	<p>Remove, recement threat;replace and tighten.</p> <p>Repaired by special welding.</p> <p>Tighten cover screw or replace gasket.</p> <p>Replace oil ring.</p>
Excess noise of vibration of machine	<ol style="list-style-type: none"> 14.Badly worn bearing. 15.Badly worn gear. 16.Bent or sprung shaft. 17.Lose of foundation bolts. 	<p>Replace bearing.</p> <p>Replace gear.</p> <p>Replace shaft.</p> <p>Tight foundation bolts.</p>

TROUBLE	PROBABLE CAUSES	REMEDY
Chatter	<p>18. Clamp of workpiece in from loose status.</p> <p>19. Spindle bearing thrust too loose.</p> <p>20. Headstock is not tight with bedway.</p> <p>21. Excess clearance between carriage and bedway.</p> <p>22. Excess clearance in cross or compound slide.</p> <p>23. Cutting angle of cutting tool is not correct.</p> <p>24. Edge of cutting tool has been worn-out.</p> <p>25. Weak of tool shank and too long for extension.</p> <p>26. Tool fixed to holder not tight enough.</p> <p>27. Unbalances of workpiece or chuck when high speed revolution.</p> <p>28. Front point of cutting tool not in correct position.</p>	<p>Tighten clamp.</p> <p>Adjust bearing thrust.</p> <p>Tighten headstock screw.</p> <p>Adjust carriage back clamp.</p> <p>Adjust taper gib.</p> <p>Regrind tools to correct cutting angles.</p> <p>Regrind cutting tool.</p> <p>Replace with rigid tools or reset the tools.</p> <p>Tighten tool again.</p> <p>Balance or reduce spindle speed revolution.</p> <p>Reset cutting tool.</p>
Bending, when long workpiece cutting.	<p>29. Feed valve too large.</p> <p>30. Workpiece too thin or too long.</p>	<p>Reduce feed valve size.</p> <p>Use follow rest and adjust position of tool.</p>
Accuracy of product fails.	31. Accuracy fails in machining.	Check the accuracy of correlation between products and machine (ref. Accuracy chart.)
Uneasy to hold gear change lever.	32. Set spring broken or too weak.	Adjust adjusting screw or replace the spring.

TROUBLE	PROBABLE CAUSES	REMEDY
Misalignment of chuck with main spindle.	33. Incorrect position of cam.	Adjust cam and lock in proper position.
Uneasy to cut thread.	34. Excessive clearance of lead screw in axial direction. 35. Excessive clearance between saddle and cross slide or cross slide and tool post slide. 36. Worn thread or nut in cross slide or tool post slide. 36. Excessive clearance of handwheel.	Adjust the thrust nut of the lead screw holder. Adjust slide gib to proper position. Adjust or replace it. Adjust the set bushing of handwheel.
Tailstock is uneasy to clamp with bed stably.	38. Clamp handle lever too long or too short.	Adjust the adjusting nut of clamp block.

11. Parts List Assembly

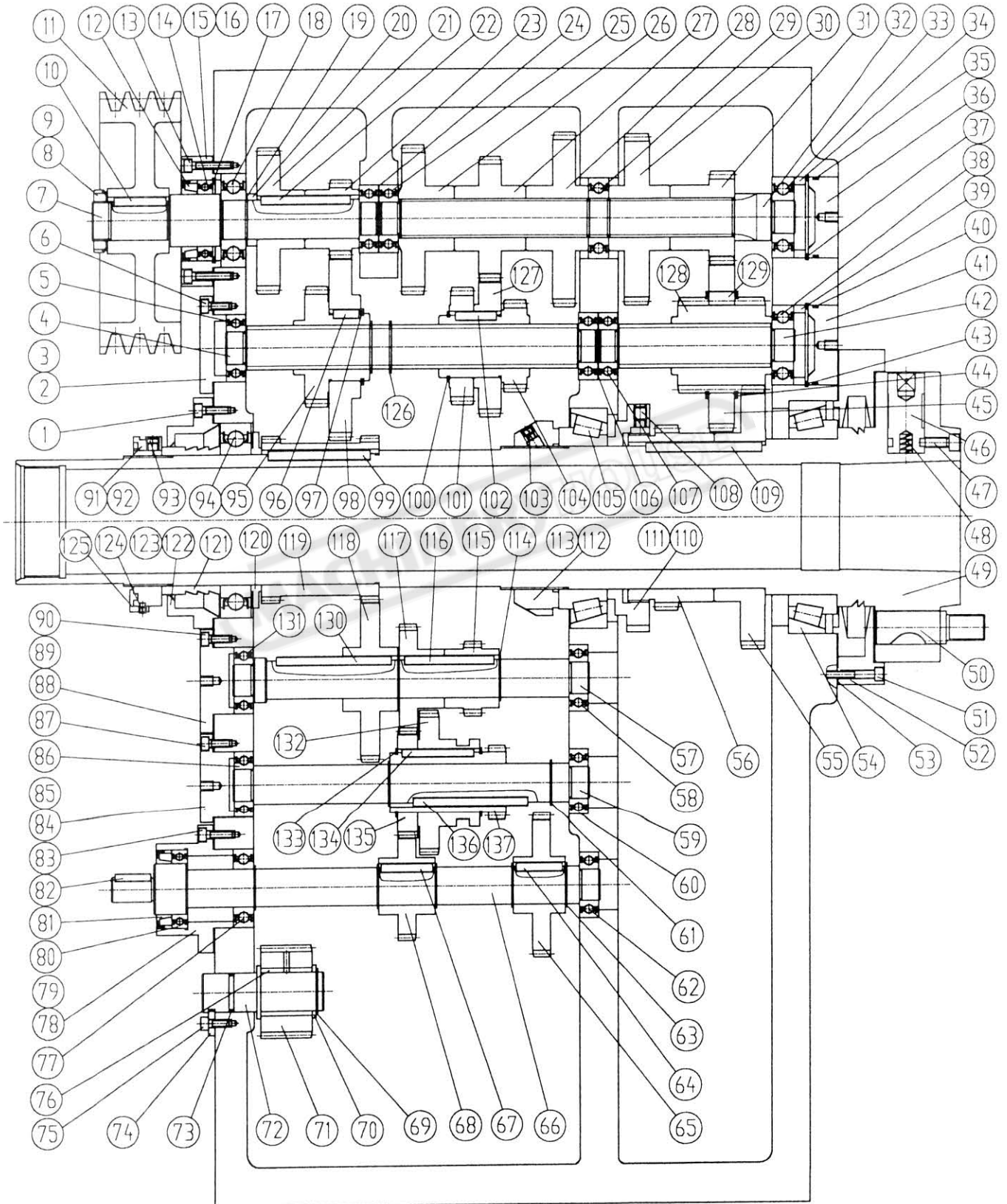

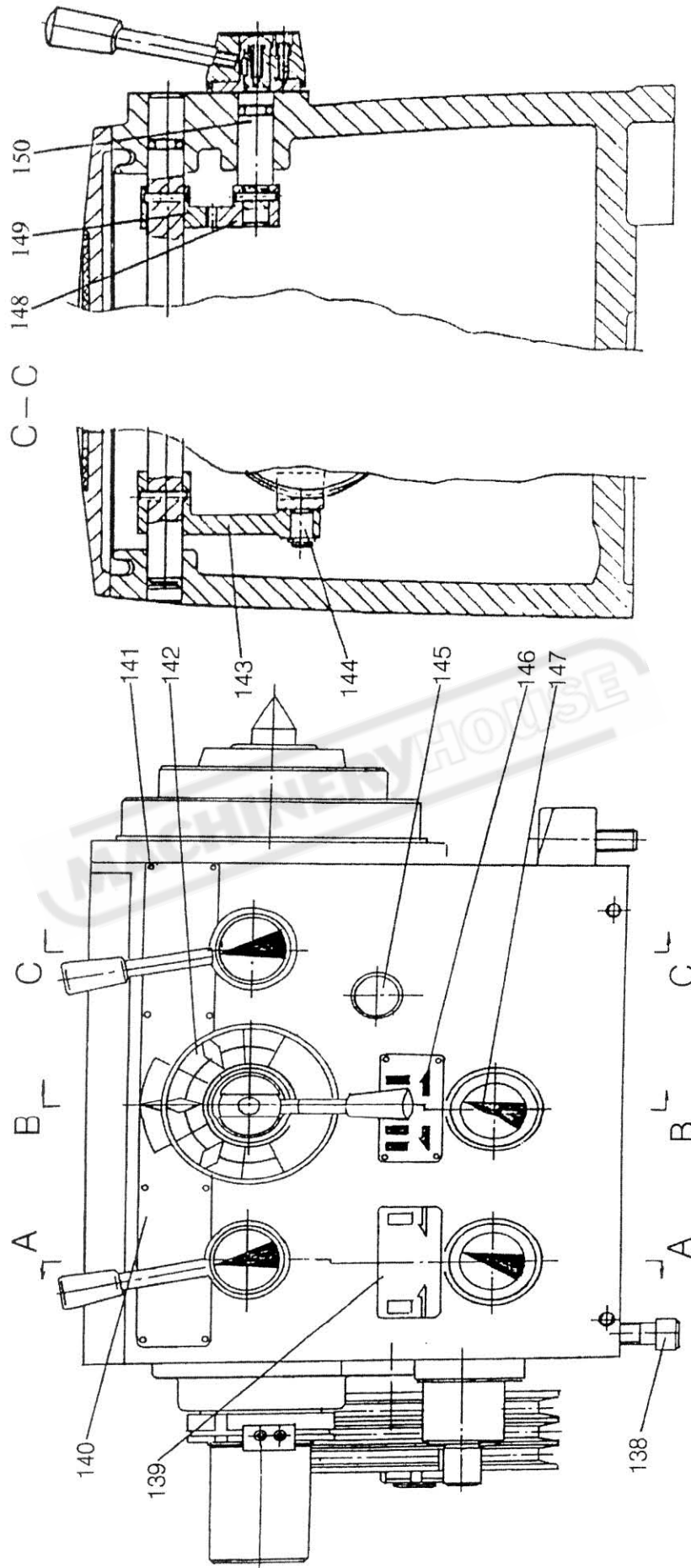

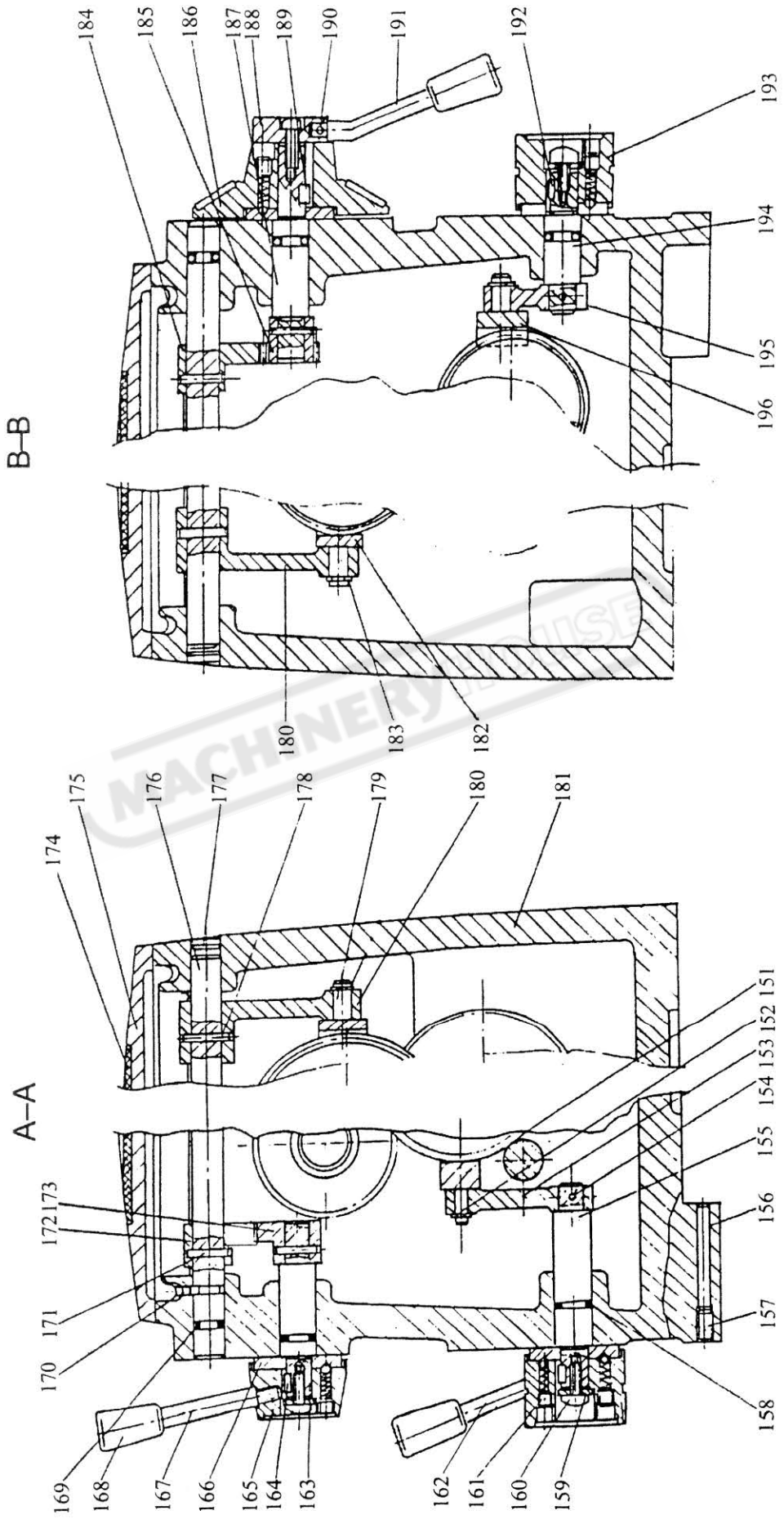

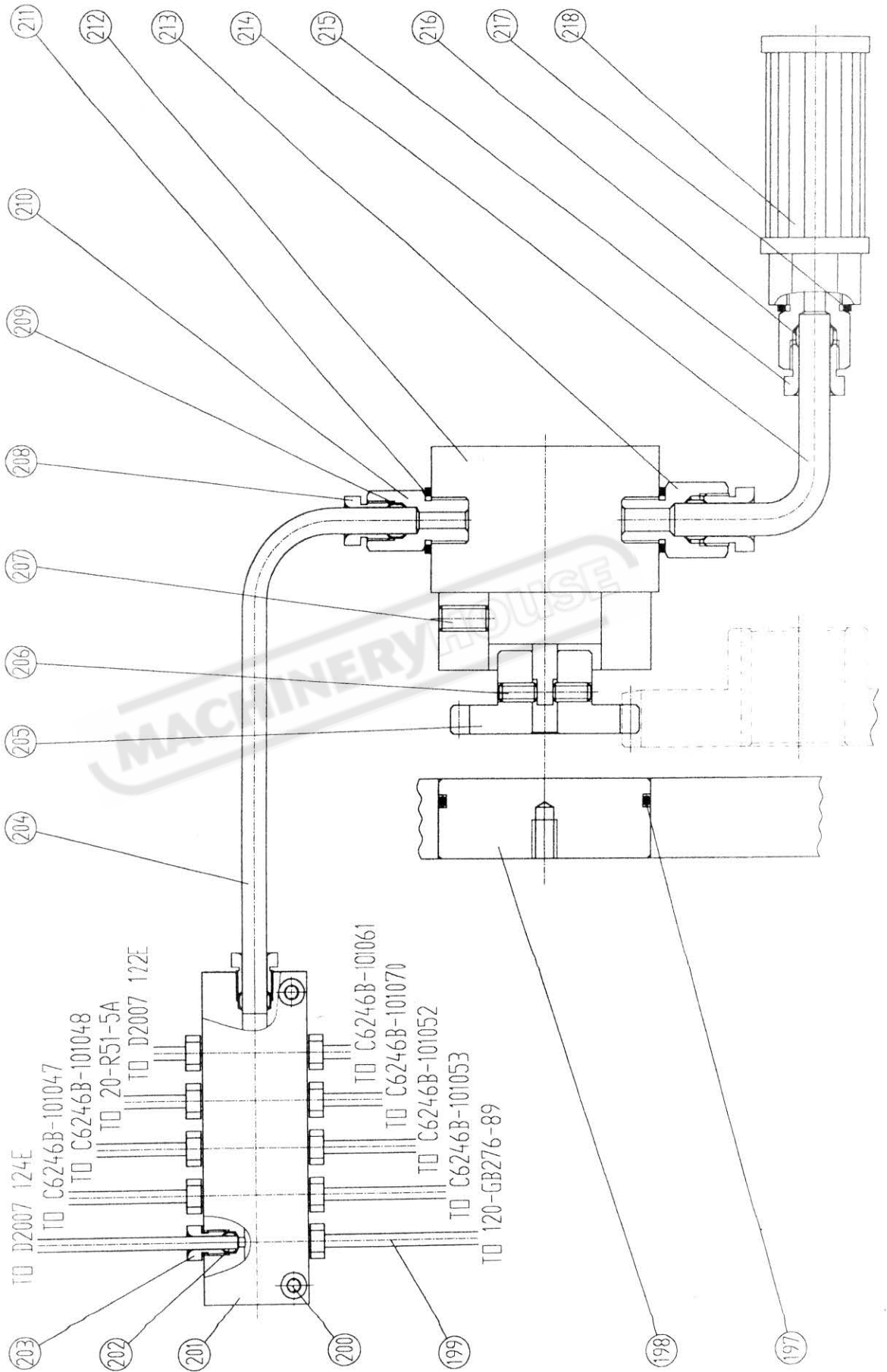

No.	Part No.	Name	Specification	Qty.
1	GB70-85	Socket Head Cap Screw	M6×20	4
2	C6246B-101079	Bearing Cover		1
3	C6246B-101079-1	Bearing Cover Seal		1
4	C6246B-101078	Spline Shaft		1
5	GB278-89	Ball Bearing	80205	1
6	GB70-85	Socket Head Cap Screw	M6×16	3
7	C6246B-101080	Input Shaft		1
8	GB812-88	Round Nut		1
9	GB858-88	Lock Washer	M30×1.5	1
10	GB1096-79	Flat Key	8×40	1
11	RUN6246-101011	Belt Pulley		1
12	HG4-692-67	Dil Seal	PD40×62×12	1
13	GB70-85	Socket Head Cap Screw	M6×30	4
14	GB278-89	Ball Bearing	1080908	1
15	C6246B-101024	Bearing Cap		1
16	C6246B-101024-1	Bearing Seat Seal		1
17	GB893.1-86	Snap Ring	62	1
18	GB278-89	Ball Bearing	80306	1
19	GB894.1-86	Snap Ring	30	1
20	C6246B-101025	Spacer		1
21	C6246B-101026	Gear		1
22	GB1096-79	Flat Key	8×70	1
23	C6246B-101027	Gear		1
24	C6246B-101028	Spacer		3
25	GB278-89	Ball Bearing	80205	2
26	C6246B-101029	Gear		1
27	C6246B-101030	Gear		1
28	C6246B-101031	Gear		1
29	GB278-89	Ball Bearing	80206	1
30	C6246B-101032	Gear		1
31	C6246B-101033	Gear		1
32	C6246B-101035	Spline Shaft		1
33	GB278-89	Ball Bearing	80305	1
34	C6246B-101034-2	Washer		1
35	GB3452.1-82	O-Ring	56×2.65	1
36	RUN6246-101019-1	Protection		1
37	GB893.1-86	Snap Ring	62	1
38	GB278-89	Ball Bearing	80305	1
39	C6246B-101034-2	Washer		1
40	GB3452.1-82	O-Ring	56×2.65	1
41	RUN6246-101019-1	Protection Cover		1
42	C6246B-101037	Spline Shaft		1
43	GB893.1-86	Snap Ring	62	1
44	GB894.1-86	Snap Ring	75	2
45	C6246B-101036	Gear		1
46	C6246B-101042	Cam Lock for D1-8		6
47	C6246B-101044	Screw for D1-8		6
48	RUN6246-101082-1	Spring		6
49	C6246B-101049-1	Spindle		1
50	C6246B-101050	Cam Screw for D1-8		6

No.	Part No.	Name	Specification	Qty.
51	GB70-85	Socket Head Cap Screw	M6×40	5
52	C6246B-101051	Front Bearing Cover	D1-8	1
53	C6246B-101051-1	Front Bearing Cover Seal		1
54	GB297-84	Ball Bearing	D2007124E	1
55	C6246B-101048	Gear		1
56	C6246B-101047	Gear		1
57	C6246B-101069	Shaft		1
58	GB278-89	Ball Bearing	80205	1
59	C6246B-101065	Shaft		1
60	GB278-89	Ball Bearing	80205	1
61	GB894.1-86	Snap Ring	30	2
62	GB278-89	Ball Bearing	80205	1
63	GB894.1-86	Snap Ring	30	5
64	GB1096-79	Flat Key	8×36	1
65	C6246B-101054	Gear		1
66	C6246B-101064	Output Shaft		1
67	GB1096-79	Flat Key	8×40	1
68	C6246B-101058	Gear		1
69	GB894.1-86	Snap Ring	30	1
70	C6246B-101059	Spacer		1
71	C6246B-101060	Stationary Pulley		1
72	C6246B-101061	Stationary Pulley Shaft		1
73	GB1235-76	O-Ring	30×2.4	1
74	RUN6246-101048	Spacer		1
75	GB70-85	Socket Head Cap Screw	M6×16	1
76	C6246B-101060-1	Brass		1
77	GB278-89	Ball Bearing	80206	1
78	C6246B-101063	Bearing Seat		1
79	C6246B-101063-1	Bearing Seat Seal		1
80	GB278-89	Ball Bearing	1080908	1
81	HG4-692-67	Oil Seal	PD40×62×12	1
82	GB1096-79	Flat Key	6×28	1
83	GB70-85	Socket Head Cap Screw	M6×20	3
84	C6246B-101067	Bearing Cover		1
85	C6246B-101067-1	Bearing Cover Seal		1
86	GB278-89	Ball Bearing	80205	1
87	GB70-85	Socket Head Cap Screw	M6×16	13
88	C6246B-101068	Bearing Cover	80305	1
89	C6246B-101068-1	Bearing Cover Seal		1
90	GB70-85	Socket Head Cap Screw	M6×16	3
91	C6246B-101074	Lock Nut		1
92	C624610101074-1	Brass		1
93	GB79-85	Socket Head Set Screw	M10×10	1
94	GB276-89	Ball Bearing	120	1
95	C6246B-101077	Gear		1
96	GB1096-79	Flat Key	8×20	1
97	GB894.1-86	Snap Ring	52	1
98	C6246B-101076	Gear		1
99	GB1096-79	Flat Key	10×80	1
100	GB894.1-86	Snap Ring	48	1

No.	Part No.	Name	Specification	Qty.
101	C6246B-101039	Gear		1
102	GB1096-79	Flat Key	8×32	1
103	GB79-85	Socket Head Set Screw	M8×10	3
104	C6246B-101041	Gear		1
105	GB297-84	Ball Bearing	D2007122E	1
106	C6246B-101028	Spacer		3
107	GB278-89	Ball Bearing	80205	2
108	GB79-85	Socket Head Set Screw	M10×16	1
109	GB1096-79	Flat Key	10×90	1
110	C6246B-101046	Lock Nut		1
111	C6246B-101046-1	Brass		1
112	C6246B-101045	Lock Nut		1
113	C6246b-101045-1	Brass		1
114	GB894.1-86	Snap Ring	30	2
115	C6246B-101052	Gear		1
116	GB1096-79	Flat Key	8×70	1
117	C6246B-101053	Gear		1
118	C6246B-101066	Gear		1
119	C6246B-101070	Gear		1
120	C6246B-101071	Shaft Ring		1
121	C6246B-101072	Oil Ring		1
122	C6246B-101075	Rear Bearing Cover		1
123	C6246B-101075-1	Rear Spindle Bearing Cover Seal		1
124	GB79-85	Socket Head Set Screw	M6×8	4
125	C6246B-101073	Balance Block		2
126	GB894.1-86	Snap Ring	34	2
127	C6246B-101040	Gear		1
128	C6246B-101038	Gear		1
129	C6246B-101036-1	Flat Key		2
130	GB1096-79	Flat Key	8×90	1
131	GB278-89	Ball Bearing	80205	1
132	C6246B-101056	Gear		1
133	GB894.1-86	Snap Ring	48	2
134	GB1096-79	Flat Key	6×56	1
135	C6246B-101057	Gear		1
136	GB1096-79	Flat Key	8×90	1
137	C6246B-101055	Gear		1
138	GB70-85	Socket Head Cap Screw	M16×55	3
139	C6246B-101098	Plate		1
140	C6246B-101006	Plate		1
141	GB827-85	Rivet	2×5	15
142	C6246B-101007	Plate		1
143	C6246B-101018	Lever		1
144	C6246B-101012-1	Fork		1
145	R51-5A	Oil Sight Glass	A20	1
146	RUN6246-101100	Plate		1
147	RUN6246-101099	Plate		1
148	C6246B-101079	Gear		1
149	C6246B-101005	Gear		1
150	RUN6246-101065	Shaft		1

No.	Part No.	Name	Specification	Qty.
151	C6246B-101008	Fork		1
152	GB894.1-86	Circlip	10	5
153	C6246B-101009	Lever		1
154	GB879-86	Spring Pin	5×26	2
155	C6246B-101017-1	Shaft		1
156	RUN6246-101080	Pin		2
157	GB79-85	Socket Head Set Screw	M10×25	2
158	GB1235-76	O-Ring	22×2.4	5
159	RUN6246-101070-1	Washer		4
160	RUN6246-101088	Screw		5
161	GB77-85	Socket Head Set Screw	M8×8	6
162	C6246B-101010	Lever		2
163	RUN6246-101065	Shaft		1
164	GB1096-79	Flat Key	5×12	3
165	RUN6246-101071	Handle		3
166	RUN6246-101067	Fix Plate		5
167	RUN6246-101072	Lever		2
168	1.307/30	Knob	BM10	5
169	GB1235-76	O-Ring	20×2.4	6
170	GB79-85	Socket Head Set Screw	M6×6	3
171	GB879-86	Spring Pin	5×26	1
172	C6246B-101005	Gear		1
173	C6246B-101004	Gear		1
174	C6246B-101003	Cover Dress		1
175	C6246B-101002	Headstock Cover		1
176	C6246B-101023	Shaft		3
177	RUN6246-101083	Plug		3
178	GB879-86	Spring Pin	5×30	1
179	C6246B-101021	Fork		1
180	C6246B-101022	Lever		1
181	C6251A-04-01	Headstock		1
181	C6256A-04-01	Headstock		1
182	C6246B-101012	Fork		1
183	GB894.1-86	Circlip	12	2
184	C6246B-101005-1	Gear		1
185	C6246B-101004-1	Gear		1
186	RUN6246-101077-1	Handle		1
187	RUN6246-101065-1	Shaft		1
188	RUN6246-101077-2	Block		1
189	GB1096-79	Flat Key	5×12	1
190	GB879-86	Spring Pin	4×20	1
191	RUN6246-101077-3	Lever		1
192	GB1096-79	Flat Key	5×12	2
193	RUN6246-101077A	Handle		1
194	C6246B-101017	Shaft		1
195	C6246B-101016	Lever		1
196	C6246B-101015	Fork		1
197	GB1235-76	O-Ring	68×3.1	1
198	C6246B-101082	Protection		1
199	GB1527-79-M-T3	Brass Tube	4×0.75	1

No.	Part No.	Name	Specification	Qty.
200	GB70-85	Socket Head Cap Screw	M5×25	2
201	C6246B-101084	Manifold		1
202	B1061C	Double Taper Sheath		11
203	15326C	Tie-in		11
204	GB1527-79-M-T3	Brass Tube	8×0.75	1
205	C6246B-101081	Gear		1
206	GB80-85	Screw	M6×12	2
207	GB80-85	Screw	M6×16	1
208	25567	Tie-in		2
209	B145C	Double Taper Sheath		2
210	C6246B-101086	Conjunctional Block		1
211	GB52-2	Washer	14	2
212	SNBY2.510.5	Motor	M14×1.5	1
213	C6246B-101087	Conjunctional Block		1
214	GB1527-79-M-T3	Brass Tube	10×0.75	1
215	25568	Tie-in		2
216	25677	Double Taper Sheath		2
217	GB52-2	Washer	18	1
218	Wu-16×180-J	Filter		1

MACHINERYHOUSE

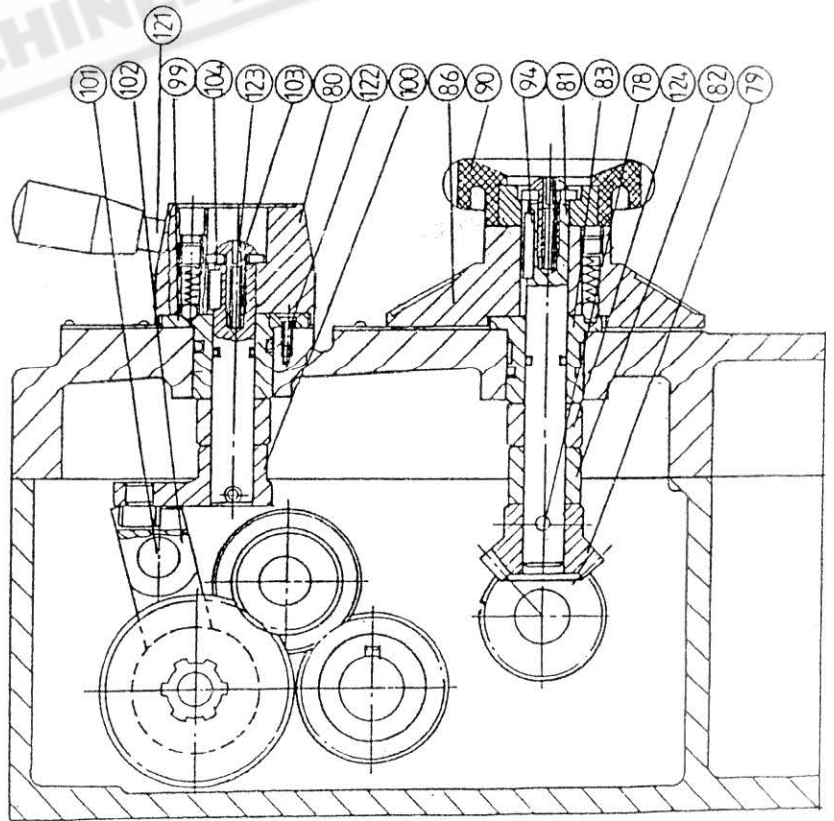
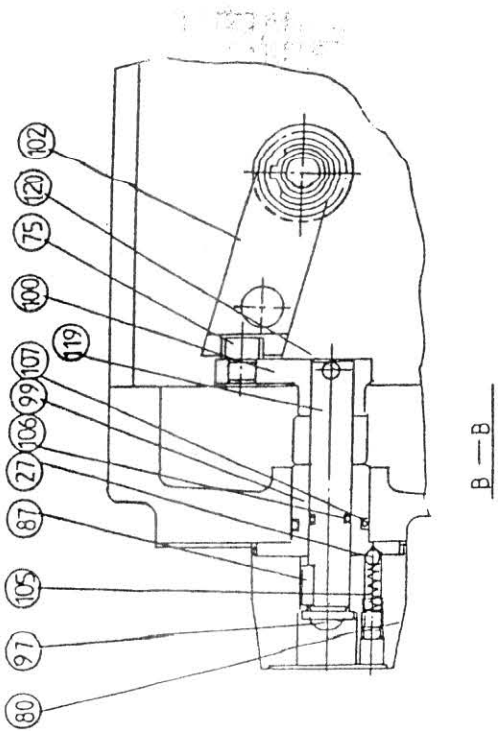
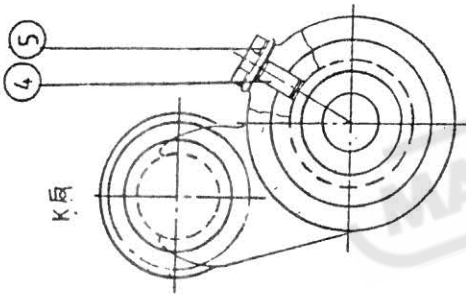
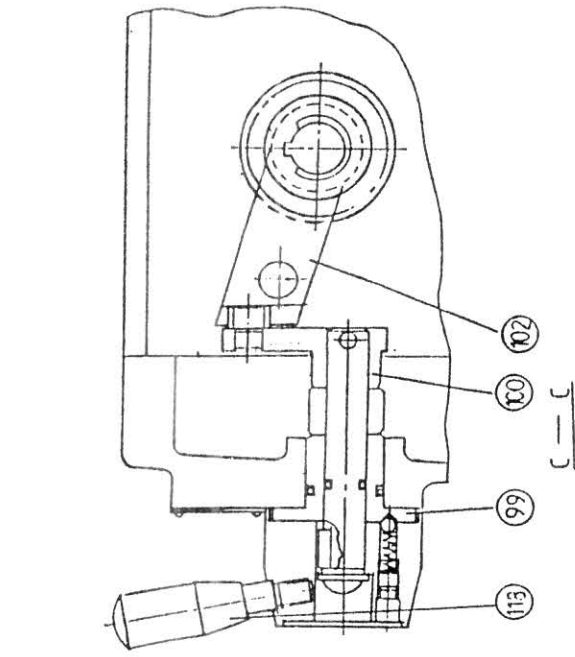

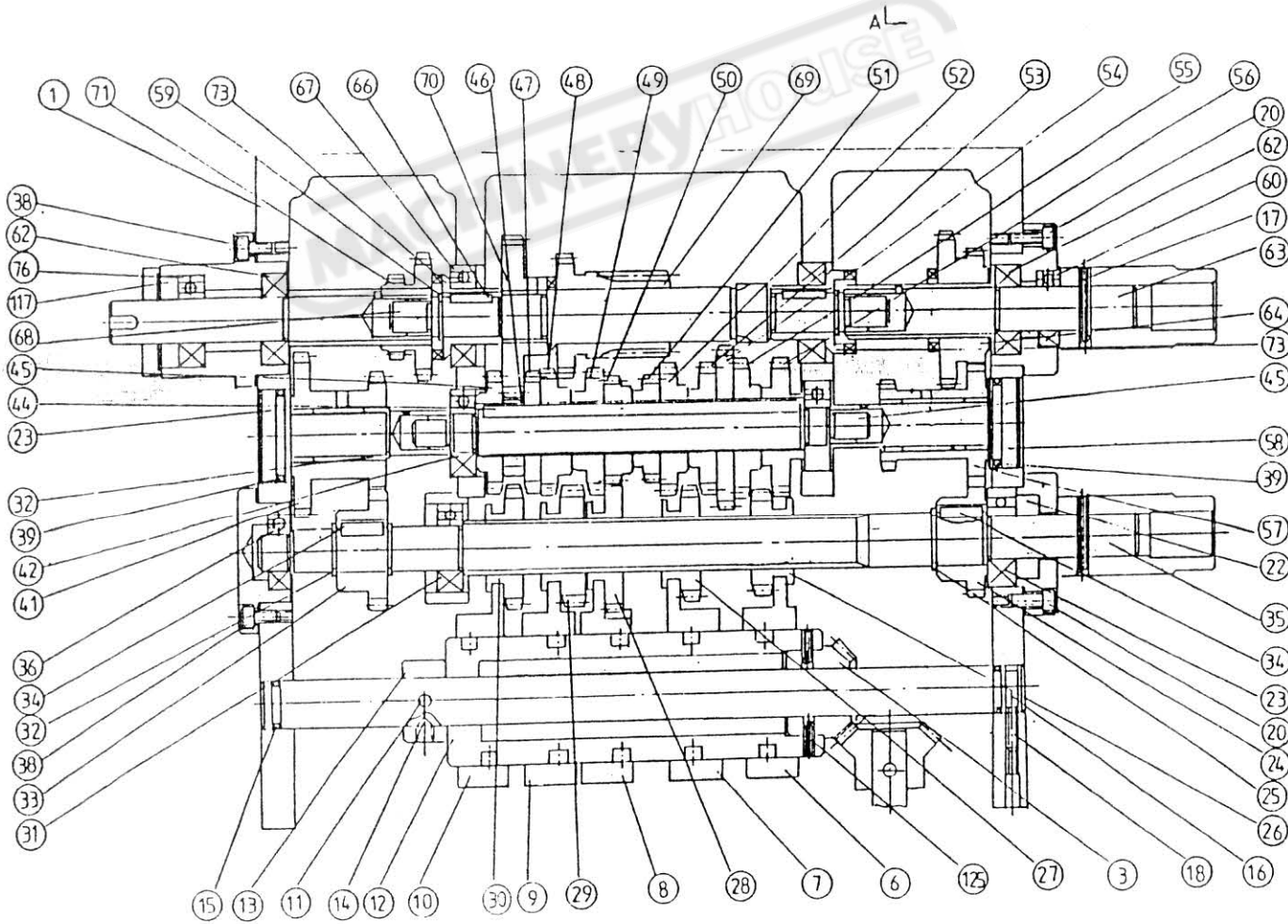
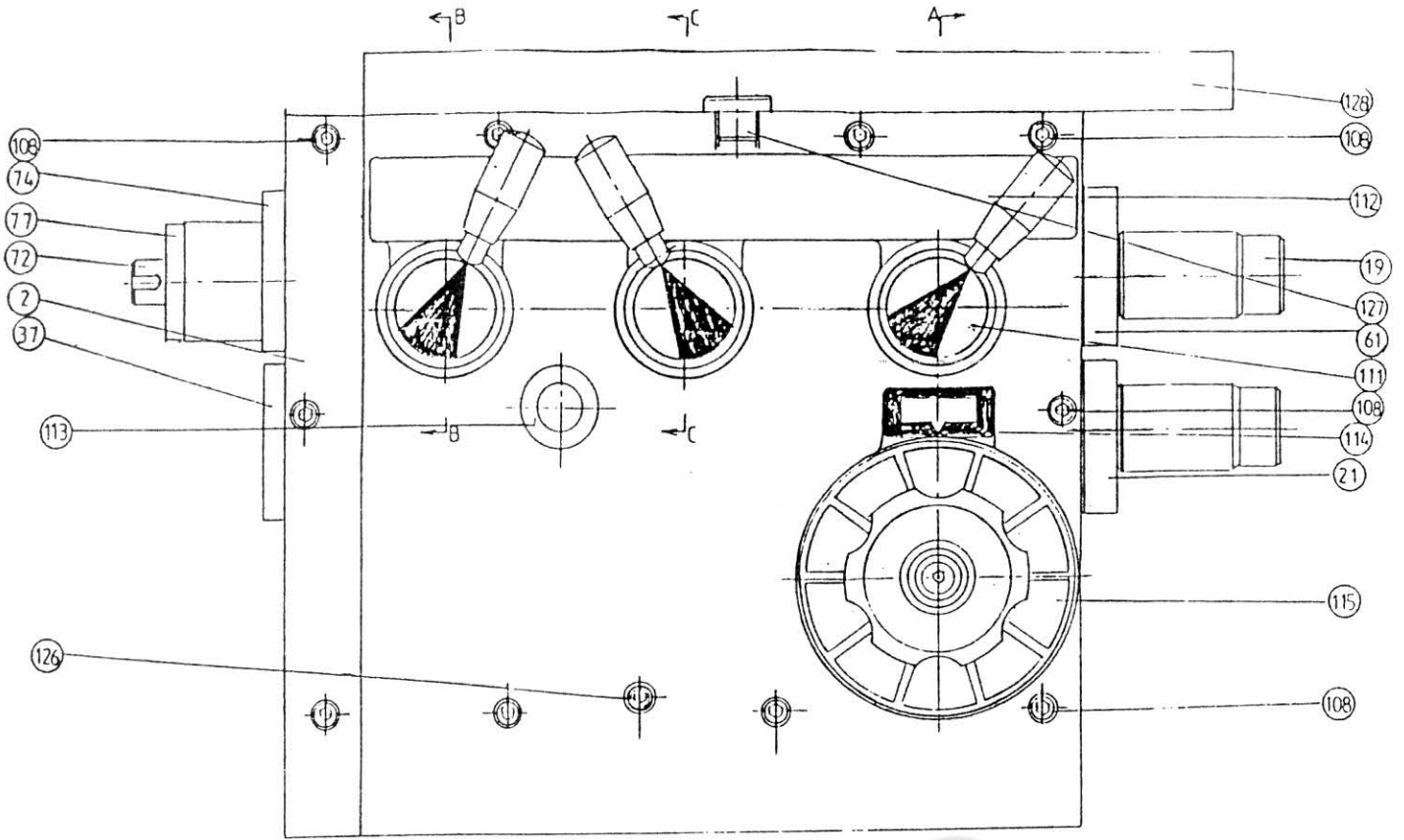

Ref. No.	Parts No.	Description	No. OFF/MC
1.	102001-00	Gear Box.....	1
2.	C6251A-05-02	Front Cover.....	1
3.	102003-00	Gear-Drive Bevel.....	1
4.	102064-00	Fixed Pin.....	1
5.	102001-00-01	Pin-Split..... 02.5.....	5
6.	102004-00	Claw-Shifer.....	1
7.	102005-00	Claw-Shifer.....	1
8.	102006-00	Claw-Shifer.....	1
9.	102007-00	Claw-Shifer.....	1
10.	102008-00	Claw-Shifer.....	1
11.	102001-00-02	Spring Pin 05.....	2
12.	102009-00	Cam Shifter.....	1
13.	102010-00	H-Shaft.....	1
14.	102001-00-03	Socket Set Screw M8XP1.25X8L.....	1
15.	102001-00-04	O-Ring P18.....	2
16.	102011-00	H-Shaft.....	1
17.	102001-00-05	Spring Pin 05X38L.....	2
18.	102001-00-06	Socket Set Screw M6XP1.0X20L.....	2
19.	C6251A-05-03	Collar-Linkage.....	2
20.	102001-00-07	Socket Cap Screw M6XP1.0X16L.....	6
21.	102013-00	Cap-Right.....	1
22.	102001-00-08	Oil Seal TC20X40X10.....	1
23.	102001-00-09	Ball Bearing #6204.....	1
24.	102014-01	Gear.....	1
25.	102001-00-10	Snap Ring STW25.....	1
26.	102015-00	Gear.....	1
27.	102016-00	Gear.....	1
28.	102017-00	Gear.....	1
29.	102018-00	Gear.....	1
30.	102019-00	Gear.....	1
31.	102001-00-11	Ball Bearing #6004.....	3
32.	102001-00-12	Snap Ring STW20.....	4
33.	102020-00	Gear.....	1
34.	102001-00-13	Key 6X6X20L.....	2
35.	102021-00	G-Shaft.....	1
36.	102001-00-14	Ball Bearing #6003.....	1
37.	102022-00	Cap.....	1
38.	102001-00-15	Socket Head Cap Screw M6XP1.0X12L.....	6
39.	102001-00-16	O-Ring P36.....	2
40.	102023-00	E-Shaft.....	1
41.	102024-00	Gear.....	1
42.	102001-00-17	Ball Bearing #6203.....	2
43.	102025-00	D-Shaft.....	1
44.	102001-00-18	Key 6X6X146L.....	1
45.	102026-00	Gear.....	1
46.	102027-00	Gear.....	1
47.	102028-00	Gear.....	1
48.	102029-00	Gear.....	1
49.	102030-00	Gear.....	1
50.	102031-00	Gear.....	1
51.	102032-00	Gear.....	1
52.	102033-00	Gear.....	1
53.	102034-00	Gear.....	1
54.	102035-00	Gear.....	1
55.	102036-00	Gear.....	1
56.	102037-00	Gear.....	1
57.	102038-01	Gear.....	1
58.	102039-00	F-Shaft.....	1
59.	102001-00-19	Snap Ring STW18.....	2
60.	102001-00-20	Thrust Bearing #51104.....	2
61.	102040-00	Cap.....	1

Ref. No.	Parts No.	Description	No OFF/MC
62.	102001-00-21	Ball Bearing #6004DV.....	3
63.	102041-00	C-Shaft.....	1
64.	102042-01	Gear.....	1
65.	102043-00	Clutch.....	1
66.	102001-00-22	Key 4X4X20L.....	2
67.	102001-00-23	Ball Bearing #6005.....	2
68.	102044-00	A-Shaft.....	1
69.	102045-00	Gear.....	1
70.	102046-00	Gear.....	1
71.	102048-00	Gear.....	1
72.	C6251A-05-04	B-Shaft.....	1
73.	102047-00	Clutch.....	1
74.	102050-00	Cap.....	1
75.	102073-00	Fork.....	3
76.	102001-00-24	Ball Bearing #6004.....	1
77.	C6251A-05-05	Spacer.....	1
78.	102001-00-25	Spring Pin 05X30L.....	1
79.	102060-00	Gear-Drive Bevel.....	1
80.	102065-00	Hub.....	3
81.	102055-01	Shaft.....	1
82.	102062-02	Spacer.....	1
83.	102058-00	Detent Plate.....	1
84.	102001-00-26	O-Ring P26.....	1
85.	102001-00-27	O-Ring P12.....	1
86.	102063-00	Selecting Dial.....	1
87.	102001-00-28	Steel Ball.....	4
88.	102001-00-29	Spring.....	1
89.	102001-00-30	Socket Set Screw M8XP1.25X8L.....	1
90.	102053-00	Wheel.....	1
91.	33-3009-00	Washer.....	1
92.	102001-00-30	Socket Set Screw M6XP1.0X20L.....	1
93.	33-3009-01	Screw.....	1
94.	102001-00-31	Key 5X5X25L.....	1
95.	102001-00-32	Plate.....	1
96.	102001-00-33	Socket Set Screw M8XP1.25X35L.....	1
97.	102001-00-34	Socket Set Screw M8XP1.25X25L.....	3
98.	102001-00-35	Spring.....	3
99.	102071-00	Detent Plate.....	1
99.	102074-00	Detent Plate.....	1
99.	102075-00	Detent Plate.....	1
100.	102066-00	Arm.....	1
100.	102067-00	Arm.....	1
100.	102068-00	Arm.....	1
101.	102077-00	Shaft.....	1
102.	102069-00	Fork.....	1
102.	102069-01	Fork.....	1
102.	102070-01	Fork.....	1
103.	102088-00	Socket Cap Screw M8XP1.25X20L.....	3
104.	33-3009-00	Washer.....	3
105.	102001-00-37	Key 5X5X15L.....	3
106.	102001-00-38	O-Ring P16.....	3
107.	102001-00-39	O-Ring P30.....	4
108.	102001-00-40	Socket Head Cap Screw M8XP1.25X10L.....	7
109.	102001-00-41	Cross Recessed Head Screw M3XP0.5.....	4
111.	102001-00-42	Plate.....	3
112.	102001-00-43	Plate.....	1
113.	102001-00-44	Oil Sight Glass.....	1
114.	102001-00-45	Plate.....	1
115.	102001-00-46	Plate.....	1
116.	102001-00-47	Cross Recessed Head Screw M3XP0.5.....	4
117.	102001-00-48	Oil-Seal TC 20X40X8.....	1

Ref. No.	Parts No.	Description	No.
118.	102001-49	Knob.....	1
119.	102072-00	Shaft.....	3
120.	102001-50	Pin.....	5
121.	102056-01	Lever.....	3
122.	102001-51	Screw.....	6
123.	102001-52	Screw.....	1
124.	102062-03	Spacer.....	1
126.	102001-54	Screw.....	1
127.	102001-55	Drain Plug.....	1
128.	C6251A-05-06	Top Cover.....	1

MACHINERYHOUSE

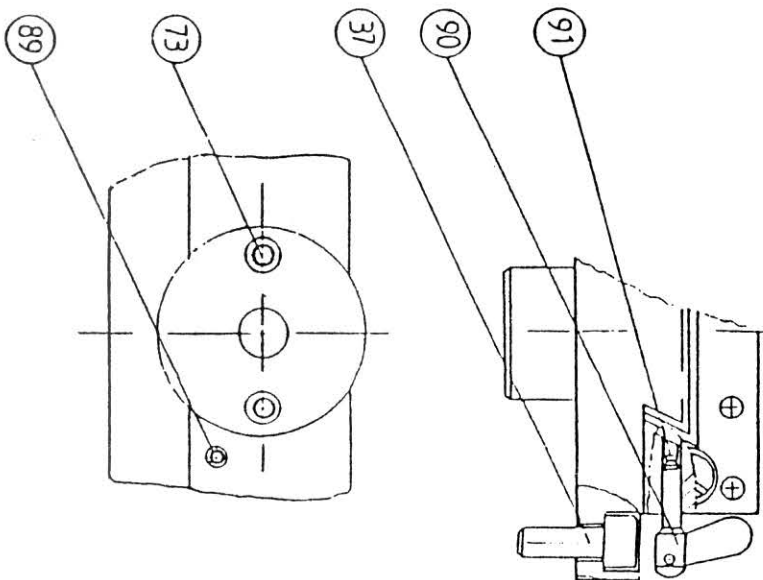
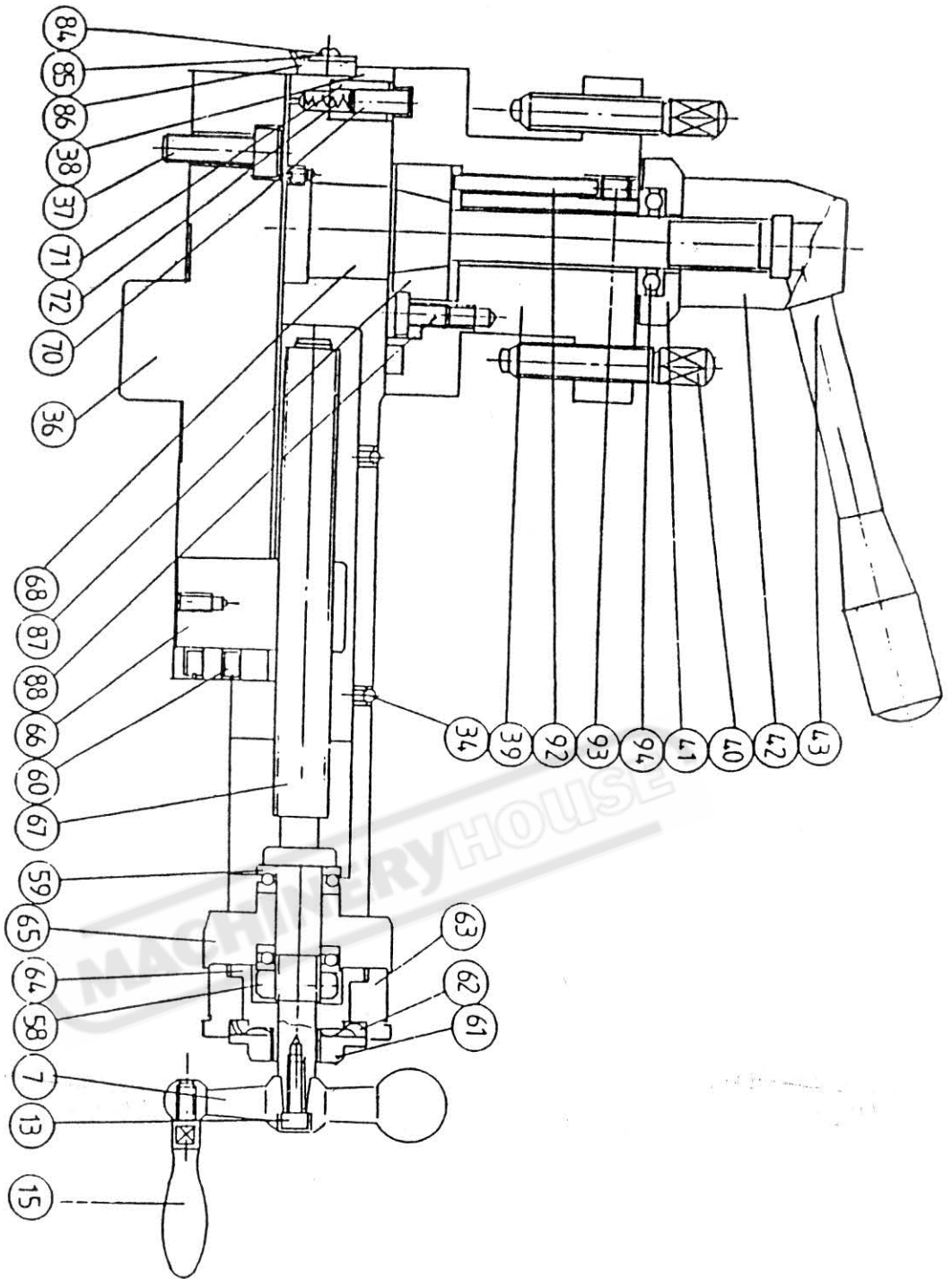

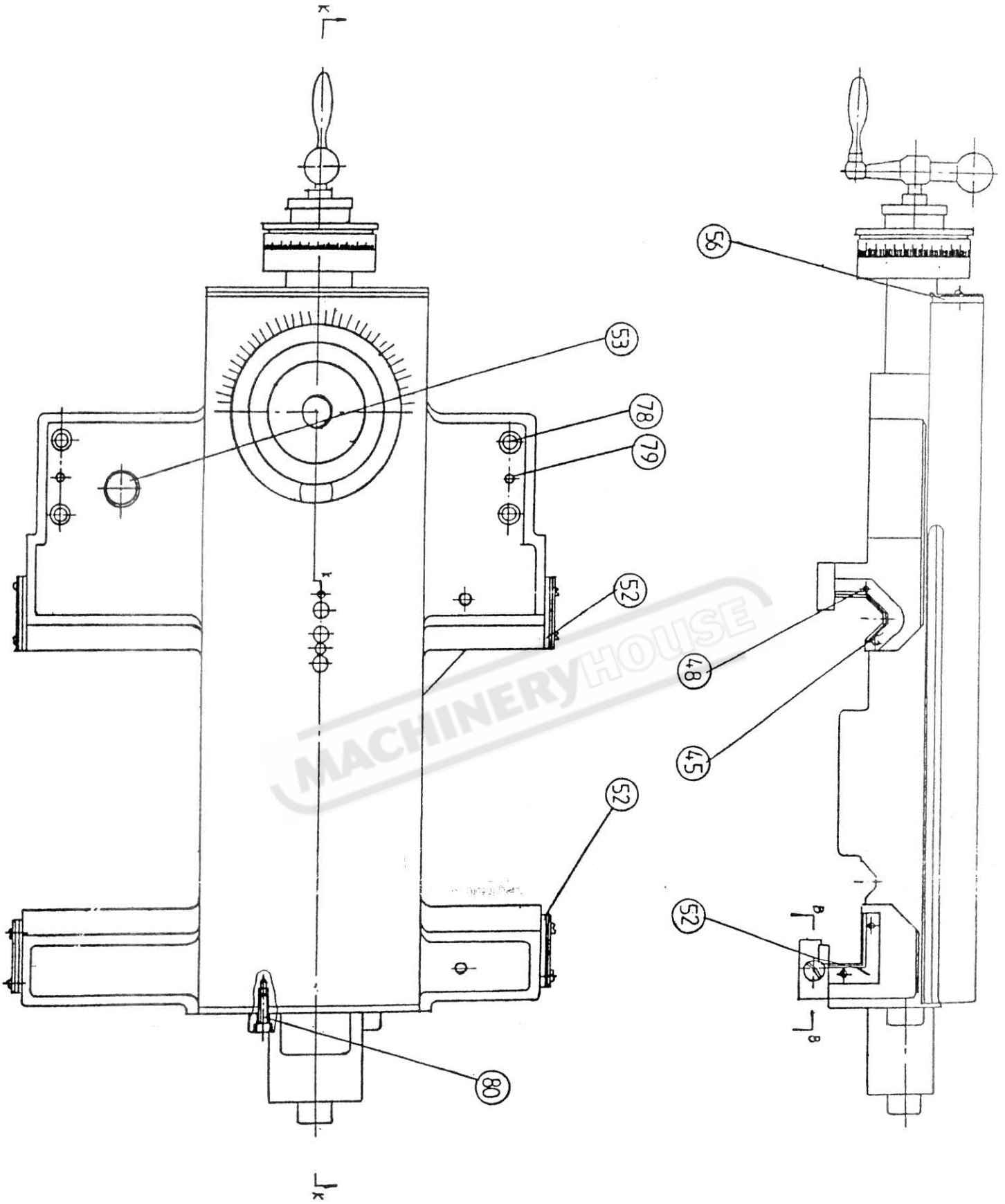

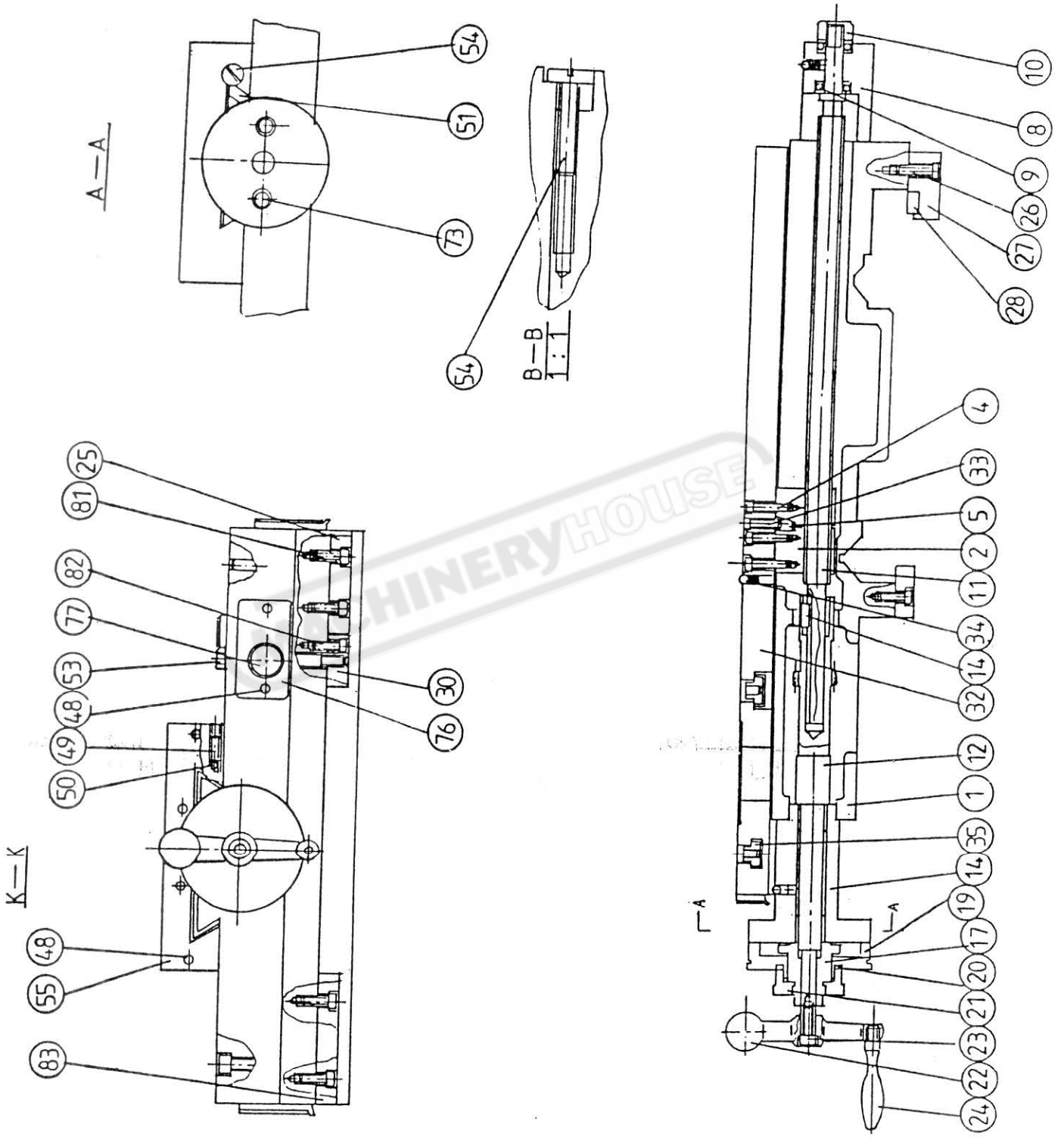

No.	Part No.	Name	Specification	Qty.
1	C6251A-07-01	Saddle		1
2	RUN6246-103003	Cross Feed Nut(Metric)		1
2	RUN6246-103003y	Cross Feed Nut(Inch)		1
4	GB70-85	Screw	M6×35	3
5	RUN6246-103004	Gib		1
6				
7	RUN6246-103048	Handle		1
8	RUN6246-103007	Bracket		1
9	GB301-84	Bearing	8101	2
10	RUN6246-103007-1	Clamp Nut		1
11	C6251A-07-21	Cross Feed Screw (Metric)		1
11	C6251A-07-21y	Cross Feed Screw (Inch)		1
12	C6251A-07-22	Cross Feed Pinion		1
13	GB70-85	Screw	M6×10	1
14	C6251A-07-22-2	Flat Key		1
15	RUN6246-103049	Handle		1
16	GB77-85	Screw	M6×5	1
17	RUN6246-103026	Clutch Dial		1
18	GB77-85	Screw	M6×8	1
19	RUN6246-103027	Cross Feed Dial		1
20	RUN6246-103025	Wave Type Washer		1
21	RUN6246-103028	Nut		1
22	RUN6246-103029	Handle		1
23	GB70-85	Screw	M8×16	3
24	RUN6246-103030A	Handle		1
25	C6251A-07-18	Gib-left-front		1
26	GB70-85	Screw	M8×30	4
27	C6251A-07-16	Holder Gib		1
28	C6251A-07-15	Gib		1
14	C6251A-07-23	Bracket		1
30	RUN6246-103019	Clamp-Carriage		1
37	GB70-85	Screw	M10×40	2
32	C6251A-07-02	Cover-Cross Sliding		1
33	GB79-85	Screw	M8×30	1
34	GB1155-79	Ball Cup	6	6
35	RUN6246-103040	Nut		3
36	C6251A-07-41	Swivel Table		1
36	C6256A-07-41	Swivel Table		1
37	GB70-85	Screw	M10×55	1
38	C6251A-07-50	Compound Rest		1
39	C6251A-07-45	Four Way Tool Post		1
40	GB83-88	Screw	M12×55	12
41	RUN6246-103060	Washer		1
42	RUN6246-103061	Clamping Handle		1
43	RUN6246-103062	Clamping Handle		1
44	RUN6246-103051	Gib		1
45	C6251A-07-12	Wiper		1

No.	Part No.	Name	Specification	Qty.
45	C6251A-07-13	Case-Wiper		2
53	RUN6246-103077	Screw		1
48	GB818-85	Screw	M4×12	12
49	GB80-85	Screw	M8×10	1
50	GB308-84	Ball	6	1
51	C6251A-07-35	Gib		1
52	C6251A-07-08	Wiper		1
52	C6251A-07-09	Wiper		1
52	C6251A-07-10	Case-Wiper		2
52	C6251A-07-11	Wiper		1
53	RUN6246-103031	Plug		1
54	RUN6246-103036	Screw		2
54	RUN6246-103037	Screw		1
55	C6251A-07-39	Case-Wiper		1
56	C6251A-07-38	Wiper		2
58	RUN103044-1	Nut		5
59	GB301-84	Thrust Bearing	8102	2
60	GB80-85	Screw	M6×10	1
61	RUN103047	Nut		1
62	RUN6246-103047-1	Wave Type Washer	8×40	1
63	RUN6246-103046-1	Dial-Compound Rest		1
64	RUN6246-103045	Collar		1
65	RUN6246-103044	Seat Compound Rest Screw		1
66	RUN6246-103043-1	Nut		1
67	RUN6246-103043	Screw-Compound Rest		1
68	C6251A-07-42	Tool Post Shaft	30×2.4	1
69	RUN6246-103053	Block-Tee		1
70	RUN6246-103057-2	Botton		1
71	RUN6246-103056-1	Sleeve		1
72	GB2089-80	Spring	1×5×18	1
73	GB70-85	Screw	M6×20	2
76	RUN6246-103068	Plate		1
76	GB68-85	Screw	M5×20	2
77	RUN6246-103064	Body Pump		1
77	RUN6246-103065	Spring		3
77	RUN6246-103066	Stopper		1
77	RUN6246-103067	Plug		1
78	GB70-85	Screw	M10×60	4
79	GB118-86	Taper Pin	8×60	2
80	GB70-85	Screw	M8×20	2
81	GB70-85	Screw	M8×25	4
82	GB70-85	Screw	M6×20	1
83	C6251A-07-20	Gib-Front		1
84	GB818-85	Screw	M4×12	4
85	C6251A-07-44	Case-Wiper		1
86	C6251A-07-43	Wiper		1
87	RUN6246-103058-1	Blacket		1
88	RUN6246-103058-2	Screw		1

No.	Part No.	Name	Specification	Qty.
89	GB77-85	Screw	M8×40	1
90	RUN6246-103052	Screw		1
91	RUN6246-103052-1	Pin		1
92	GB119-85	Pin	D6×60	3
93	GB77-86	Screw	M8×10	3
94	GB301-84	Thrust Bearing	8104	1

MACHINERYHOUSE

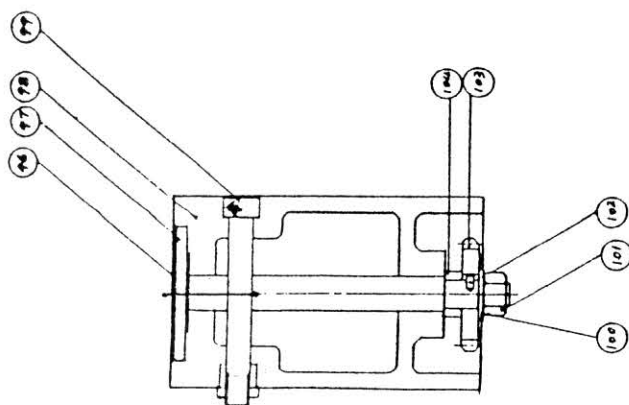
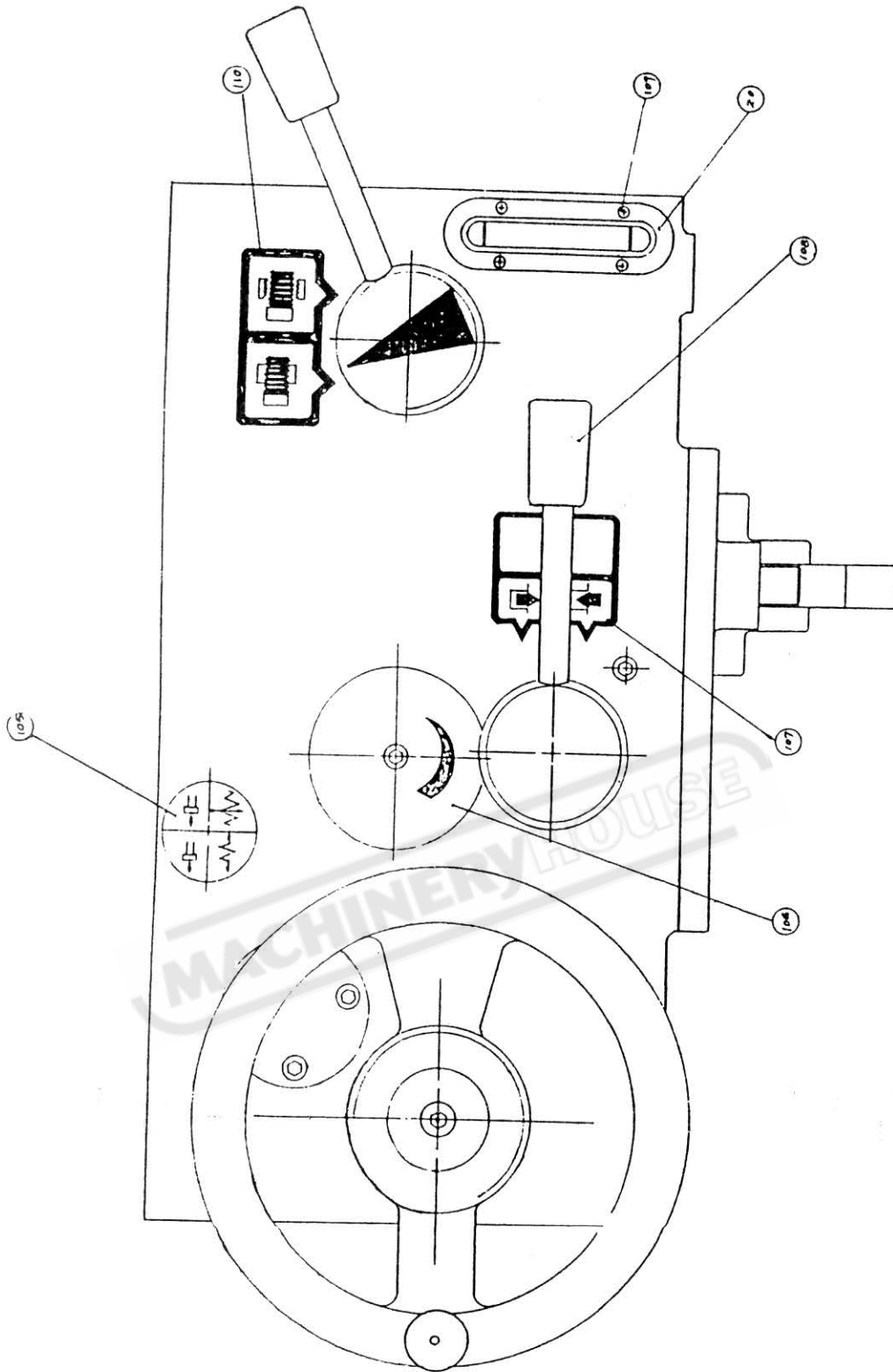

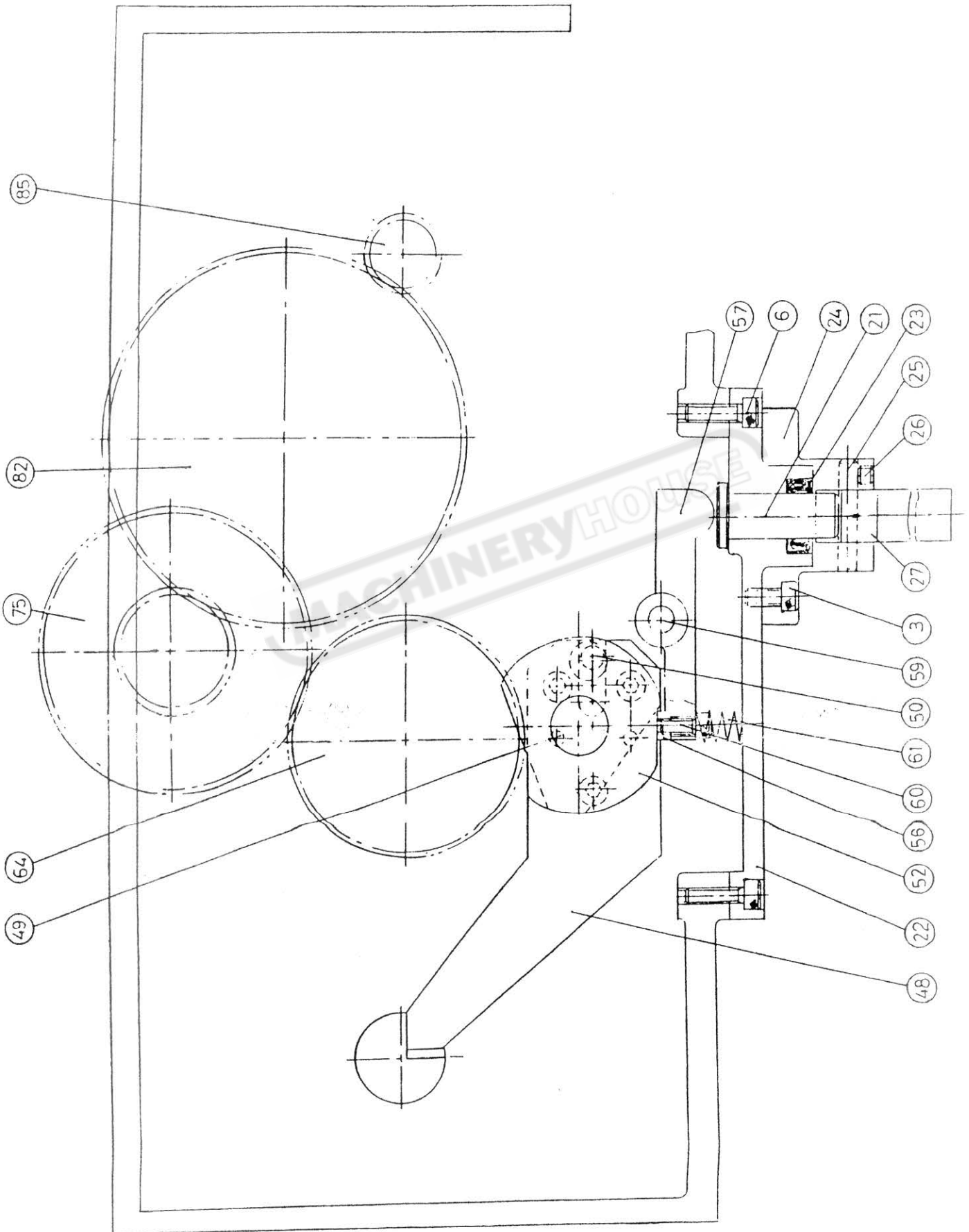

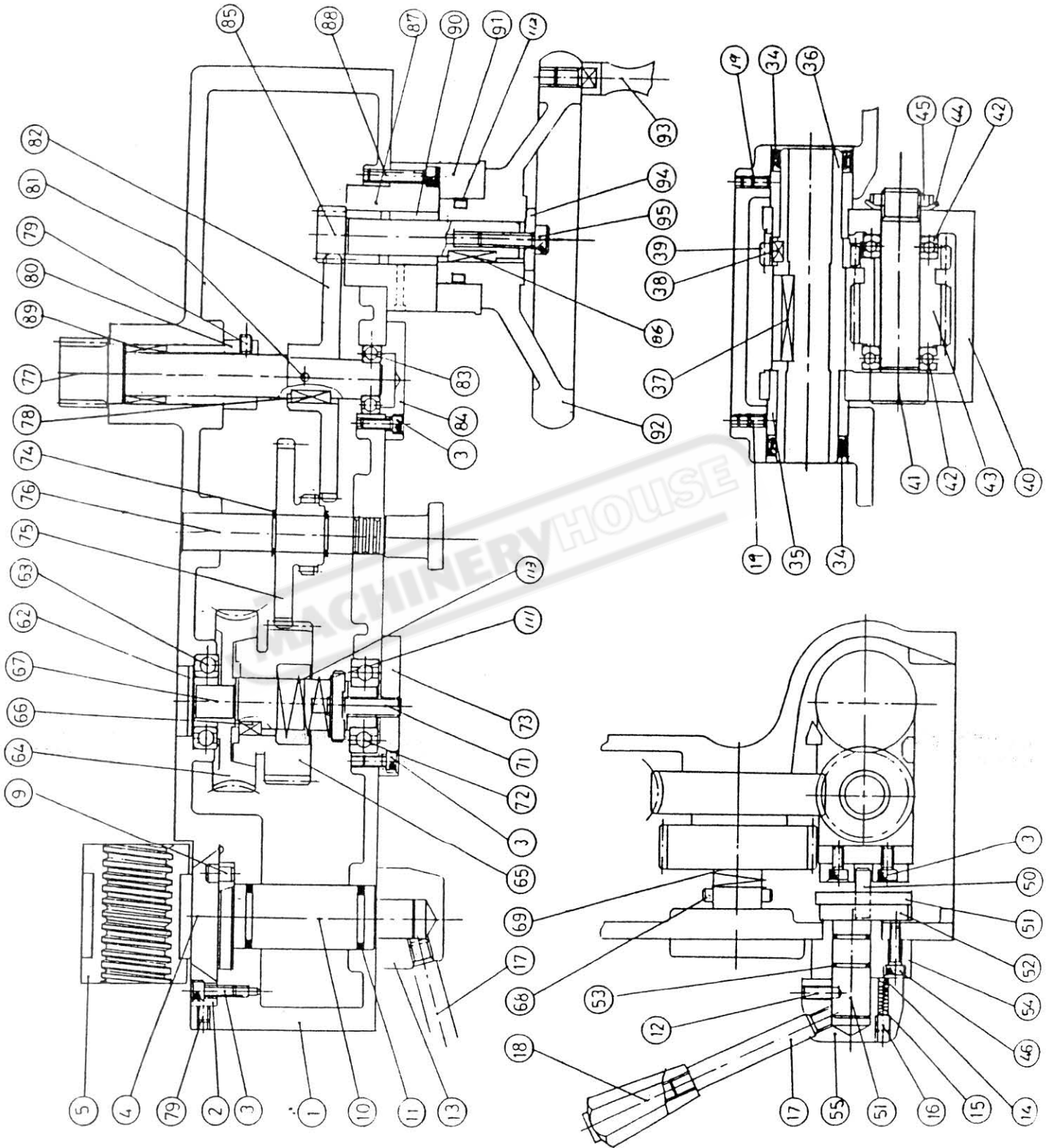

APRON

Ref. No.	Parts No.	Description	No. OFF/MC
1	104001-01	Apron (Right Hand).....	1
1.	104001-02	Apron (Left Hand).....	1
2.	104002-00	Gib.....	1
3.	104001-00-01	Socket Head Cap Screw (M6XP1.0X12L)..	12
4.	104003-01	Lead Nut Assy (Right Hand).....	1
4.	104003-02	Lead Nut Assy (Left Hand).....	1
5.	C6251A-06-01	Haft Nut (Metric).....	1
5.	104004-02	Haft Nut (Inch).....	1
6.	104001-00-02	Socket Head Cap Screw (M6XP1.0X16L)..	8
7.	104001-00-03	Socket Head Cap Screw (M6XP1.0X14L)..	1
8.	104001-00-04	Socket Head Cap Screw (M6XP1.0X10L)..	1
9.	104005-00	Key.....	2
10.	104006-01	Shaft (Right Hand).....	1
10.	104006-02	Shaft (Left Hand).....	1
11.	104001-00-05	O-Ring P26.....	2
12.	104001-00-06	Socket Head Set Screw (M8XP1.25X8L)..	2
13.	104007-00	Lever Head.....	1
14.	104001-00-07	Steel Ball (0 1/4").....	2
15.	104001-00-08	Spring (06X0.8X20L).....	2
16.	104001-00-09	Socket Head Set Screw (M8XP1.25X8L)..	2
17.	104008-00	Lever.....	2
18.	104001-00-01	Knob.....	2
19.	104001-00-11	Socket Head Set Screw (M4XP0.75X10L)..	4
20.	104001-00-12	Oil Sight.....	1
21.	104010-00	Pin.....	1
22.	104011-00	Bottom Cover.....	1
23.	104001-00-13	Oil Seal TC 15X25X7.....	1
24.	104012-00	Bracket.....	1
25.	104013-00	Pin.....	1
26.	104001-00-14	Socket Head Set Screw (M6XP1.0X6L)..	1
27.	104014-00	Lever.....	1
28.	104001-00-15	Nut (M8XP1.25).....	1
29.	104001-00-16	Socket Head Set Screw (M8XP1.25X40L)..	1
30.	104001-00-17	Socket Head Set Screw (M6XP1.0X40L)..	1
31.	104001-00-18	O-Ring P6.....	1
32.	104001-00-19	Nut (M6XP1.0).....	1
33.	104001-00-20	Drain Plug.....	1
34.	104001-00-21	Oil Seal TC 32X42X10.....	2
35.	104015-00	Bushing.....	2
36.	104016-00	Sleeve-feed Rod.....	1
37.	104001-00-22	Key 6X10X45L.....	1
38.	104001-00-23	Key 6X6X12L.....	1
39.	104017-00	Gear.....	1
40.	104018-01	Seat-Worm.....	1
40.	104018-02	Seat-Worm.....	1
41.	104019-00	Shaft.....	1
42.	104001-00-24	Thrust Bearing (#2904).....	2
43.	104020-00	Worm Gear.....	1
44.	104001-00-25	Washer-Lock 020.....	1
45.	104021-00	Nut.....	1
46.	104001-00-26	Socket Head Cap Screw (M6XP1.0X20L)..	1
47.	104022-01	Spring (Right Hand).....	1
47.	104022-02	Spring (Left Hand).....	1
48.	104023-01	Safe device block (Right Hand).....	1
48.	104023-02	Safe device block (Left Hand).....	1
49.	104001-00-27	Pin.....	1
50.	104001-00-28	Pin.....	1
51.	104026-01	Shaft (Right Hand).....	1
51.	104026-02	Shaft (Left Hand).....	1
52.	104027-00	Collar.....	1
53.	104001-00-29	O-Ring P16.....	1
54.	104028-00	Cover.....	1

APRON			
Ref. No.	Parts No.	Description	NO. OFF/MC
55.	104029-01	Hub.....	1
55.	104029-02	Hub.....	1
56.	104001-00-30	Spring Washer.....	1
57.	104030-00	Lever.....	1
58.	104001-00-31	Nut (M12XP1.25).....	1
59.	104031-00	Screw.....	1
60.	104001-00-32	Socket Head Set Screw (M5XP0.8X8L)....	1
61.	104032-00	Spring.....	1
62.	104033-00	Cover.....	1
63.	104001-00-33	Ball Bearing #6005.....	1
64.	104034-00	Worm Gear.....	1
65.	104035-00	Gear.....	1
66.	104001-00-34	Key (7X7x12L).....	1
67.	104036-00	Shaft.....	1
68.	101037-00	Pin.....	1
69.	104038-00	Spring.....	1
70.	104039-00	Spacer.....	1
71.	104001-00-35	Socket Head Set Screw (M10XP1.5X30L)...	1
72.	104001-00-36	Ball Bearing #6204.....	1
73.	104040-00	Cover.....	1
74.	104001-00-37	External Circlip.....	2
75.	104041-00	Gear.....	1
76.	104042-00	Shaft.....	1
78.	104001-00-38	Key 6X6X20L.....	1
79.	104001-00-39	Socket Head Set Screw (M6XP1.0X8L)....	1
80.	104048-00	Spacer.....	1
81.	104001-00-40	Pin (05x35L).....	1
82.	104049-00	Gear.....	1
83.	104001-00-40	Ball Bearing #6003.....	1
84.	104050-00	Cover.....	1
85.	104051-00	Shaft.....	1
86.	104001-00-41	Key (6X6X25L).....	1
87.	104052-00	Seat.....	1
88.	104001-00-42	Socket Head Set Screw (M6XP1.0X25L)...	1
89.	104053-00	Needle Bearing 20X22X30.....	1
90.	104052-01	Bushing.....	2
91.	104054-01	Dial-Rack (Metric).....	1
91.	104054-02	Dial-Rack (Inch).....	1
92.	104055-00	Hand Wheel.....	1
93.	104056-00	Handle.....	1
94.	104057-00	Washer.....	1
95.	104001-00-43	Socket Head Cap Screw (M8XP1.25X16L)...	1
96.	104001-00-44	Dial Plate.....	1
97.	104059-00	Dial Indicator Shaft.....	1
98.	104058-00	Thread Dial Body.....	1
99.	104001-00-45	Socket Head Cap Screw (M8XP1.25X70L)...	1
100.	104001-00-46	Washer.....	1
101.	104001-00-47	Nut W3/8"-16UNC.....	1
102.	104001-00-48	Pin 03X4L.....	1
103.	104060-00	Gear (Metric) 11T.....	1
103.	104061-00	Gear (Metric) 13T.....	1
103.	104062-00	Gear (Metric) 14T.....	1
103.	104063-00	Gear (Metric) 15T.....	1
103.	104064-00	Gear (Inch) 16T.....	1
103.	104065-00	Gear (Metric) 18T.....	1
104.	104046-00	Spacer.....	1
105.	104001-00-49	Plate.....	1
106.	104001-00-50	Plate.....	1
107.	104001-00-51	Plate.....	1
108.	104001-00-52	Knob.....	1
109.	104001-00-53	Screw.....	1
110.	104001-00-54	Plate.....	1
111.	104039-00	Spacer.....	1
112.	104001-00-55	Spring Leaf.....	2

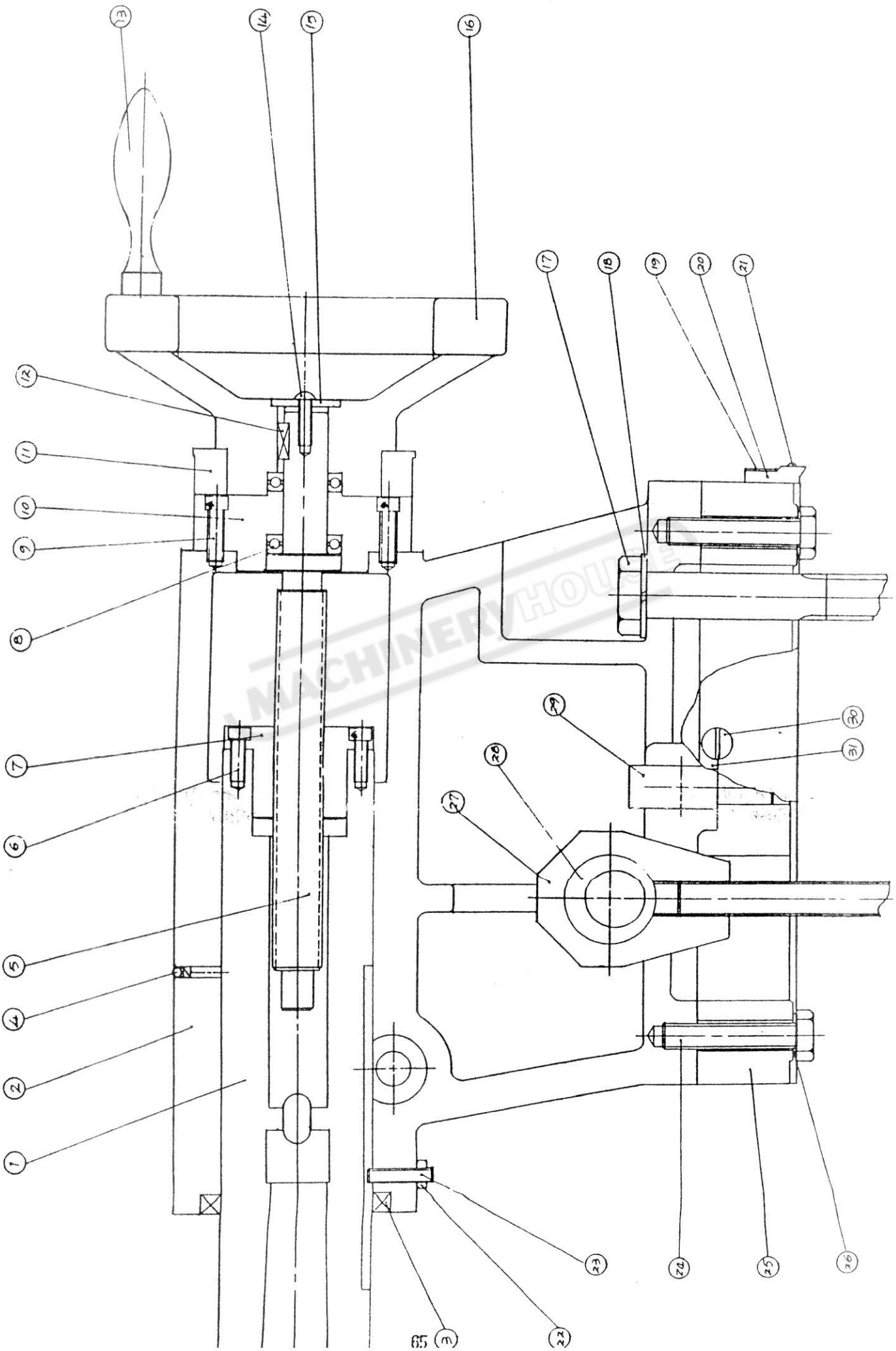

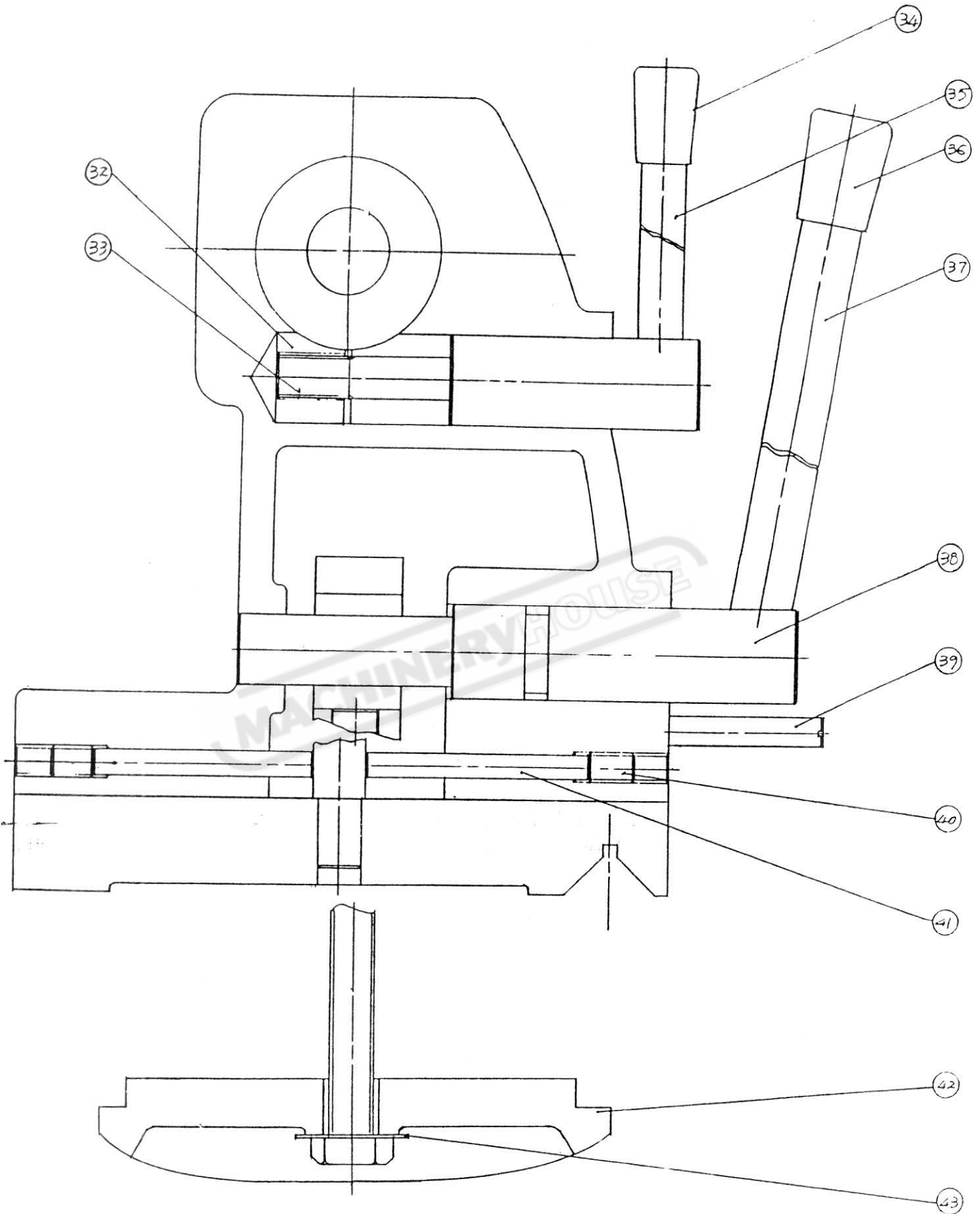

No.	Part No.	Name	Specification	Qty.
1	C6246B-105003	Tailstock Sleeve		1
2	C6251A-08-01	Tailstock Body		1
3	HG4-692-67	Oil-Seal	PD75×95×12	1
4	GB1155-79	Oil cup	10	2
5	C6251A-08A-01	Feed Screw		1
6	GB70-85	Screw	M6×16	4
7	C6246B-105005	Feed Nut		1
8	GB301-84	Thrust Bearing	8105	2
9	GB70-85	Screw	M6×16	3
10	C6246B-105006	Cap-Body End		1
11	C6246B-105009	Dial-Feed		1
12	GB1096-79	Flat Key	6×20	1
13	RUN6246-104056A	Handle		1
14	RUN6246-101088	Screw		1
14	GB80-85	Screw	M5×25	1
15	C6246B-105011	Washer		1
16	C6246B-105010	Handle Wheel		1
17	GB56-88	Nut	M20	1
18	GB95-85	Washer	20	1
19	C6251A-08-07	Case-Wiper		2
20	C6251A-08-06	Wiper		2
21	GB818-85	Screw	M4×12	4
22	GB80-85	Screw	M6×12	2
23	C6246B-105030	Pin Shaft		1
24	GB5782-86	Screw	M12×70	2
25	C6251A-08-02	Bottom Tailstock		1
25	C6256A-08-02	Bottom Tailstock		1
26	GB95-85	Washer	12	2
27	RUN6246-105018	Bolt-Clamp		1
28	RUN6246-105028	Sleeve		1
29	RUN6246-105017	Block-Adjusting		1
30	RUN6246-105020	Screw		1
31	C6246B-105012	Taper Gib Strip		1
32	C6246B-105021	Block Clamp		1
33	C6251A-08-05	Shaft		1
34	B-M10	Lever Sleeve	M10	1
35	RUN6246-105004	Lever		1
36	B-M12	Lever Sleeve	M12	1
37	RUN6246-105006	Lever		1
38	C6251A-08-04	Shaft		1
39	RUN6246-105007	Screw		1
40	GB80-85	Screw	M16×30	2
41	GB119-86	Pin Shaft	12×80	2
42	C6251A-08-03	Clamping Handle		1
43	GB5782-86	Screw	M20×100	1
43	GB95-86	Washer	20	1

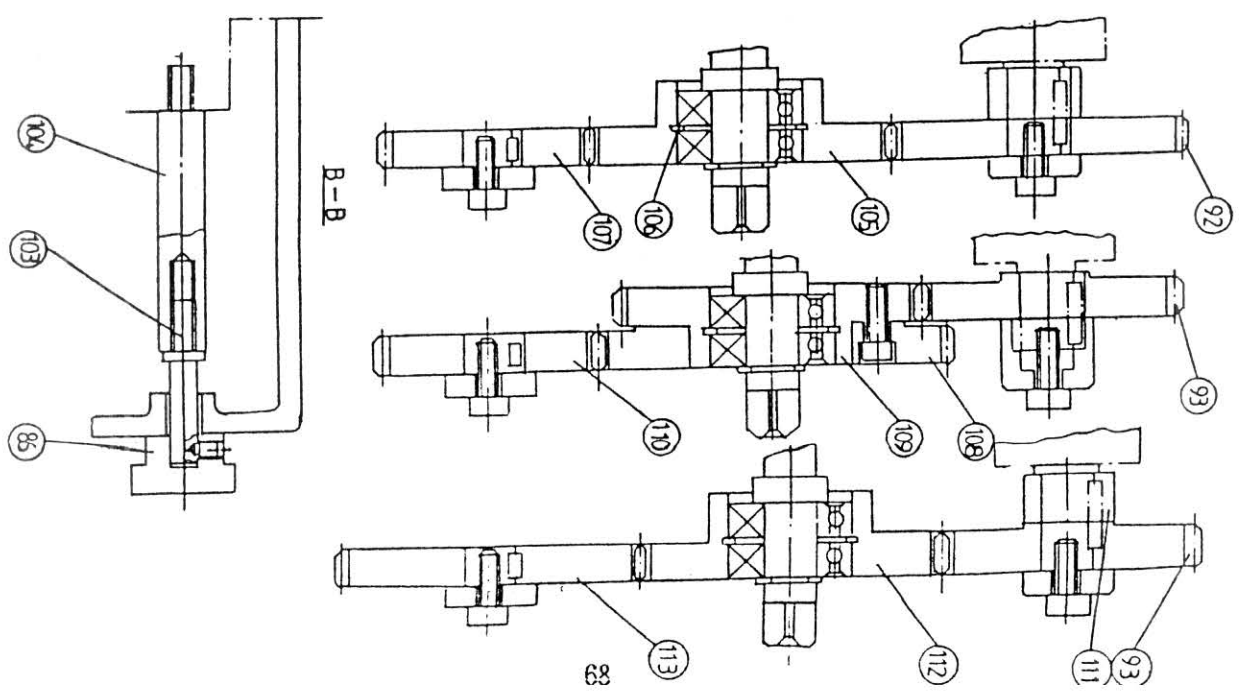
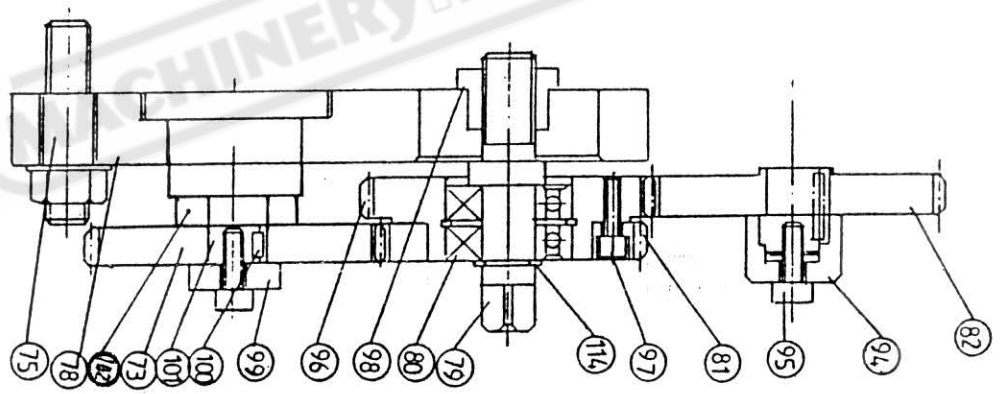
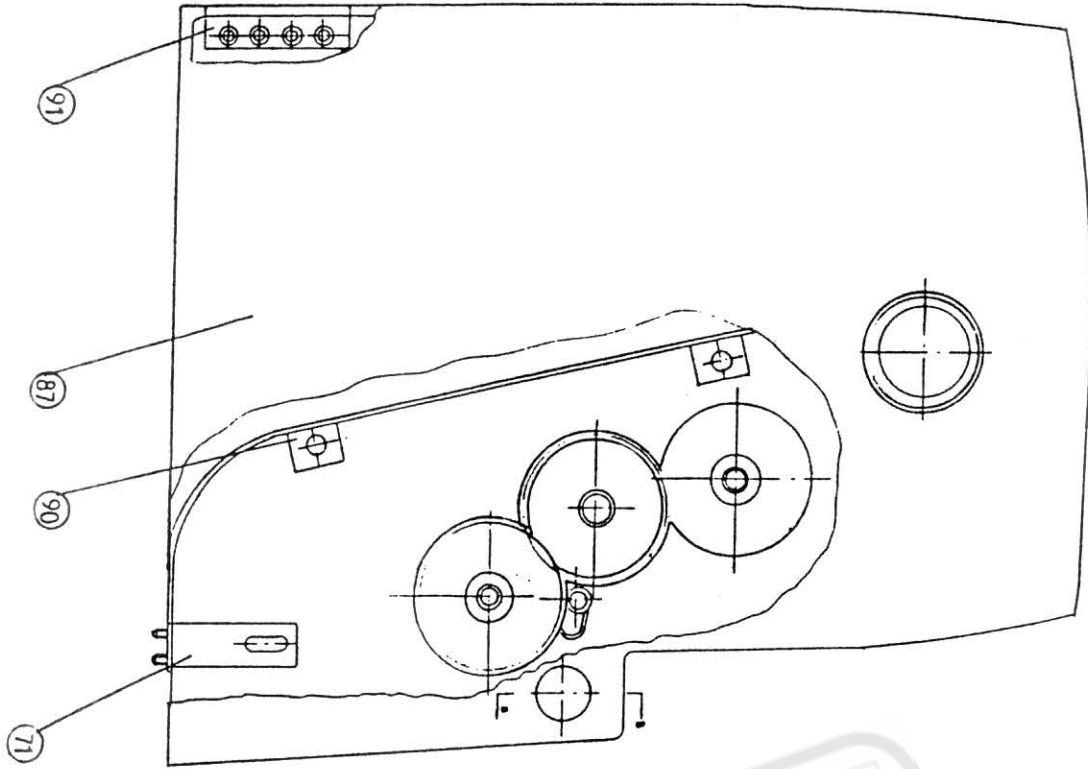

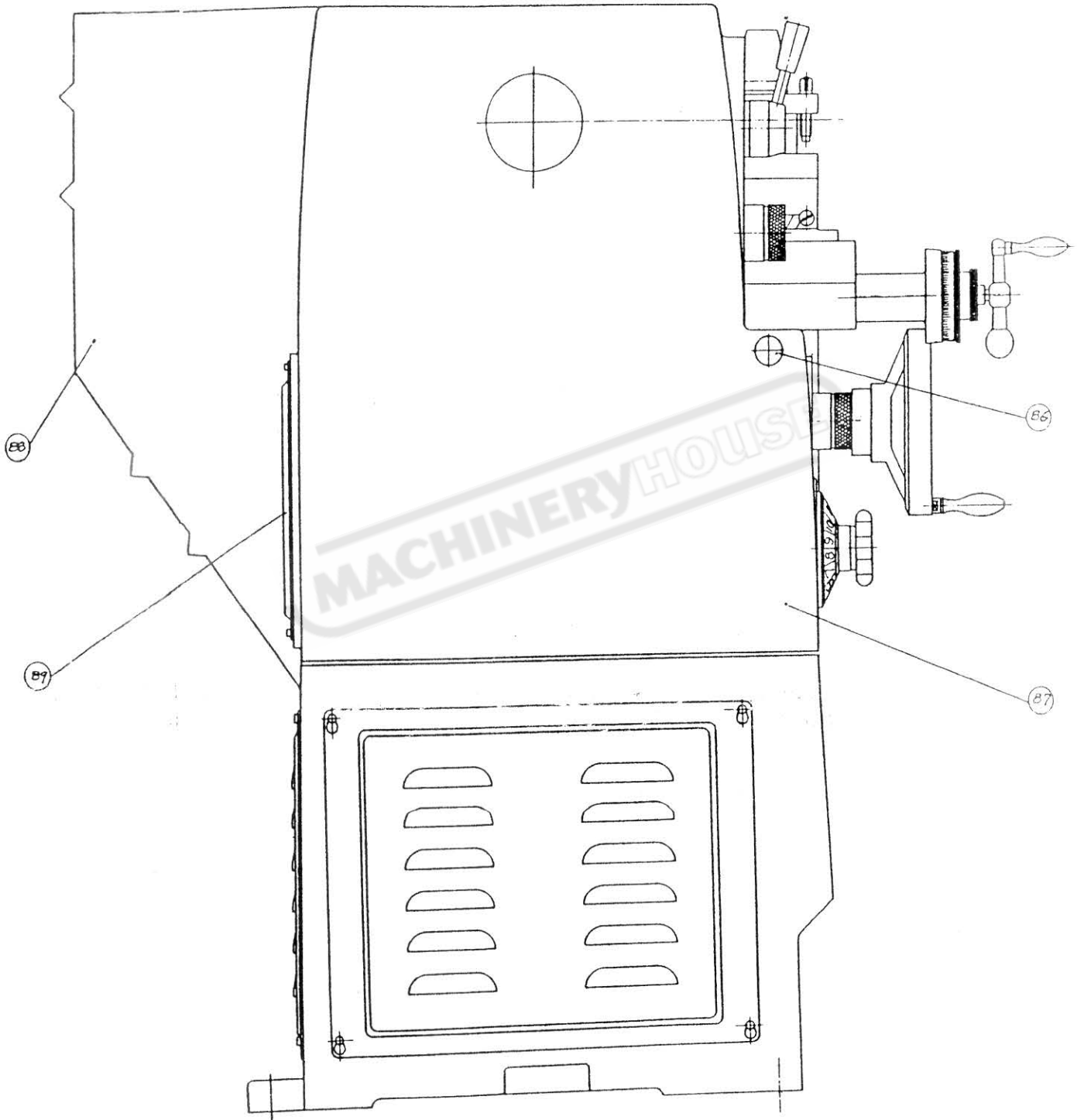

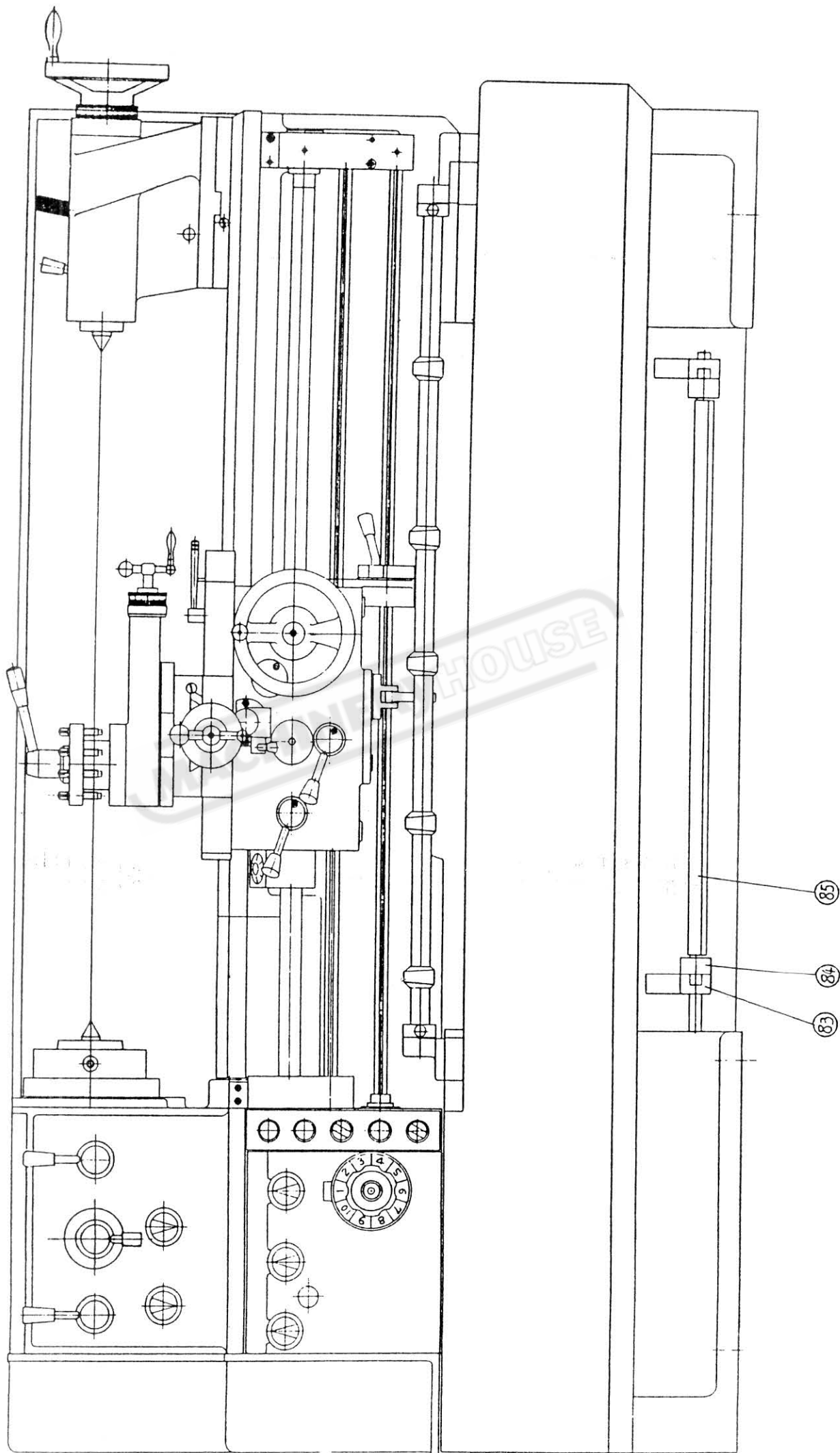

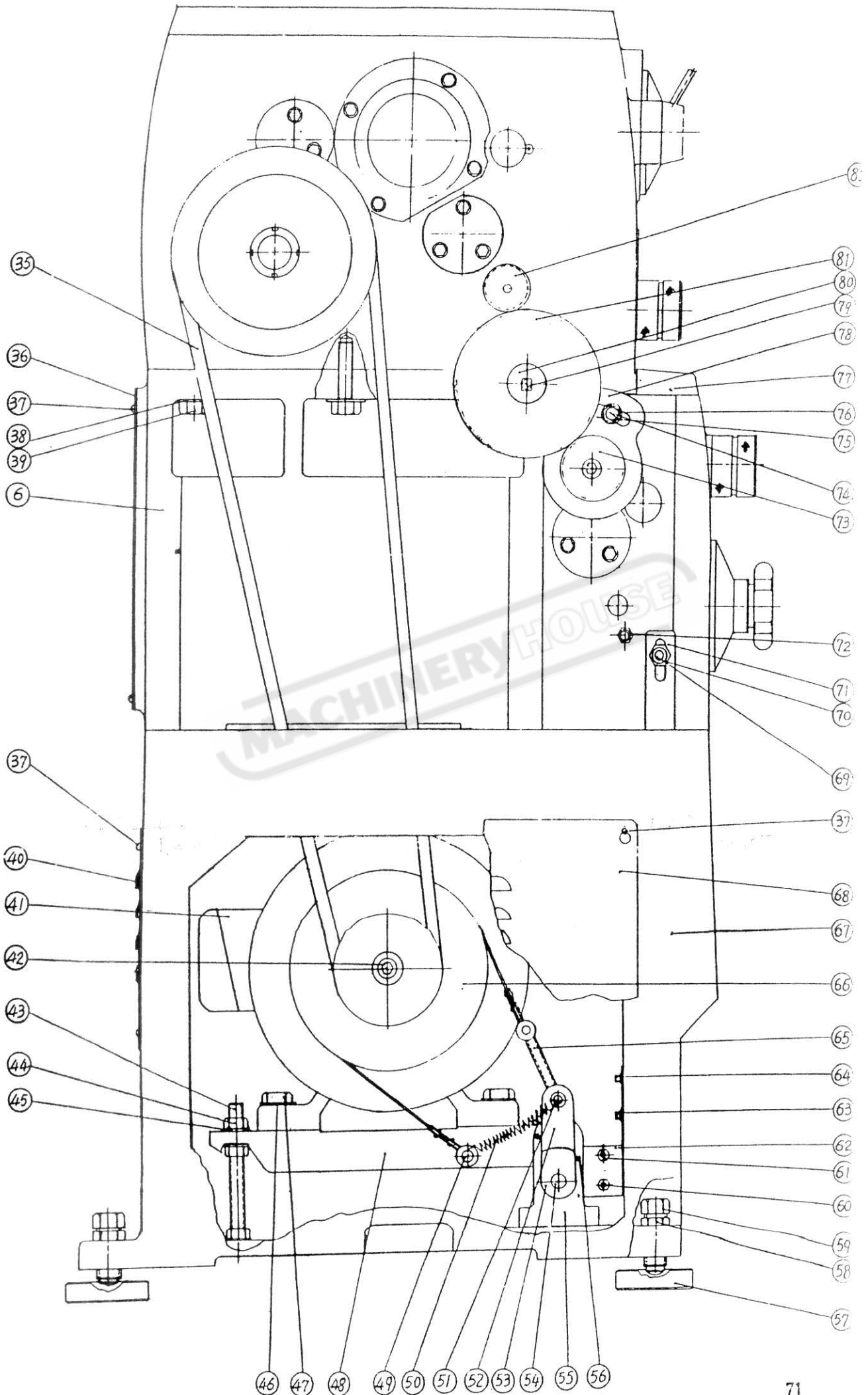

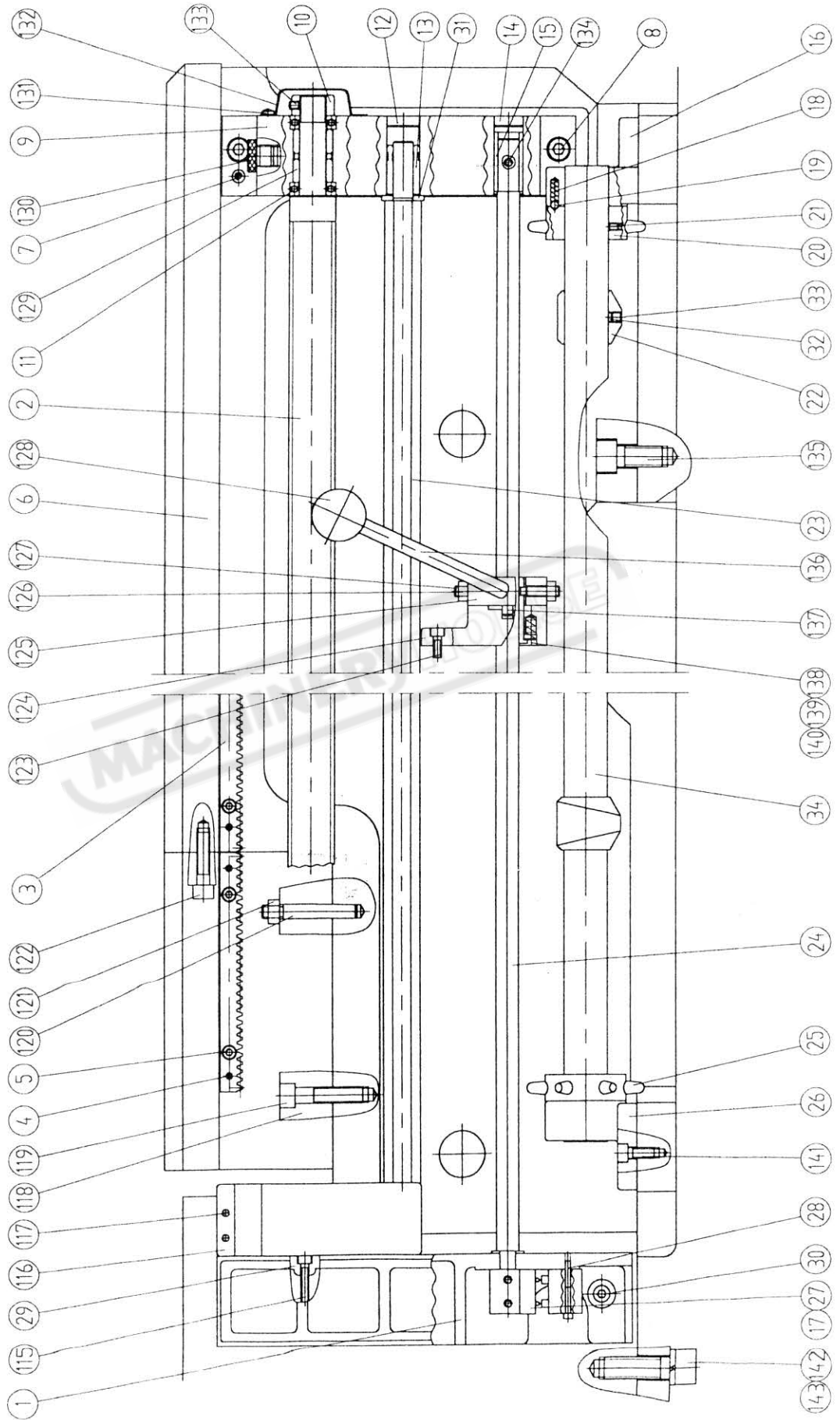

No.	Part No.	Name	Specification	Qty.
1	RUN6246-106016	Seat-Switch		1
2	C6251A-01-16	Lead Screw		1
3	C6251A-01-05	Rack		1
4	GB879-86	Spring Pin	5×30	11
5	GB70-85	Screw	M6×25	10
6	C6251A-01-01	Bed		1
7	GB118-86	Taper Pin	10×45	2
8	GB70-85	Screw	M10×40	2
9	C6251A-01-07	Bracket		1
10	C6251A-01-04	Nut		1
11	GB301-84	Thrust Bearing	8105	2
12	RUN6246-106010-1	Plug		1
13	RUN6246-106008	Bush		1
14	RUN6246-106010-02	Plug		1
15	RUN6246-106014	Bush		1
16	C6251A-01-22	Bracket		1
17	GB70-85	Screw	M6×20	2
18	Q81-1	Spring	1×5×25	1
19	GB308-84	Ball	6	1
20	RUN6246-106019-2	Star Type Ring		1
21	GB80-85	Screw	M6×8	2
22	RUN6246-106020	Cam		1
23	C6251A-01-08	Feed Rod		1
24	C6251A-01-09	Started Rod		1
25	RUN6246-106019-1	Star Type Ring		1
26	C6251A-01-21	Bracket		1
27	CM6233-2055	Cam		1
28	GB70-85	Screw	M4×40	2
29	RUN6141-106018	Seat-Pilot Light		1
30	GB70-85	Screw	M8×25	2
31	RUN6246-106010-07	Spacer		1
32	RUN6246-106020-1	Shoe Clamp		1
33	GB80-85	Screw	M8×6	4
34	C6251A-01-10	Auto Stopping Rod		1
35	GB1171-74	Belt	B76(60Hz)	1
36	GB1171-74	Belt	B77(50Hz)	1
37	GB818-85	Cross Recessed Head Screw	M6×8	12
38	GB93-86	Washer	16	2
39	GB70-85	Bolt	M16×55	2
40	RUN6246-106028-1	Cover Motor Seat		1
41	Y132M-4	Motor	7.5kw	1
42	GB70-85	Screw	M8×55	1
43	RUN106046	Screw		2
44	GB6170-86	Nut	M16	6
45	RUN6246-106079	Washer		4
46	GB97.1-86	Washer	10	4
47	GB5782-86	Bolt	M10×35	4
48	RUN6246-106034	Motor Seat		1
49	RUN6246-106050	Shaft		1
50	Q81-3	Spring	3×6×115	1

No.	Part No.	Name	Specification	Qty.
51	RUN6246-106039	Shaft		1
52	RUN6246-106040	Arm Brake		1
53	RUN6246-106037	Cam		1
54	RUN6246-106045	Shaft		1
55	RUN6246-106041	Bracket-Motor Seat		1
56	LXW5-11G1	Limited Switch		1
57	RUN6246-106069	Block-Leveling		10
58	GB6172-86	Nut	M24×2	10
59	RUN6246-106029	Bolt		10
60	GB70-85	Screw	M5×10	2
61	GB6172-86	Nut	M5	2
62	RUN6246-106091	Limited Switch Seat		1
63	GB70-85	Screw	M5×10	2
64	GB6172-86	Nut	M5	2
65	RUN6246-106047	Belt-Brake		1
66	RUN6246-106048	Belt Pully	50Hz	1
66	RUN6246-106048a	Belt Pully	60Hz	1
67	C6251A-01-03	Stand		1
68	C6251A-01-11	Cover Motor Seat		1
69	LXW5-11M	Limited Switch		1
70	LXW5-11M	Nut		1
71	RUN6246-106078	Limited Switch Seat		1
72	RUN6246-106082	Bolt		1
73	C6251A-05-07	Gear		1
73	C6256A-05-07	Gear		1
74	GB6170-86	Nut	M16	1
75	RUN6246-108063	Bolt		1
76	RUN6141-108017	Washer		1
77	C6251A-05-06	Top Cover		1
78	C6251A-05-08	Bracket		1
79	RUN6246-108004	Bolt		1
80	GB278-89	Ball Bearing	16204	1
81	C6251A-05-10	Gear		1
81	C6256A-05-10	Gear		1
82	C6251A-04-03	Gear		1
82	C6256A-04-03	Gear		1
83	RUN6246-106036	Bracket		1
84	RUN6246-106042A	Arm		1
85	C6251A-01-13	Pedal-Brake		1
86	RUN6246-106073	Screw		1
87	C6251A-04-02	Cover-End		1
87	C6256A-04-02	Cover-End		1
88	C6251A-01-15	Guard Assy		1
89	RUN6246-106071	Cover		1
90	C6251A-01-20	Plate		1
90	C6256A-01-20	Plate		1
91	C6251A-04-02-1	Hing		2
92	C6251A-05-07	Gear		1
92	C6256A-05-07	Gear		1

No.	Part No.	Name	Specification	Qty.
93	C6251A-04-03	Gear		1
93	C6256A-04-03	Gear		1
94	RUN6246-108002	Spacer		1
95	GB70-85	Screw	M8×20	1
96	C6251A-05-11	Gear		1
96	C6256A-05-11	Gear		1
97	GB70-85	Screw	M6×10	3
98	RUN6246-108005	Spacer		1
99	C6251A-05-09	Spacer		2
100	GB1096-79	Key	6×10	1
101	C6251A-05-04	Shaft		1
102	C6251A-05-05	Spacer		1
103	RUN6246-108074	Screw		1
104	C6251A-05-12	Screw		1
105	C6251A-05-11y	Gear		1
105	C6256A-05-11y	Gear		1
106	GB893.1-86	External Circlip	47	2
107	C6251A-15-01	Gear		1
107	C6256A-15-01	Gear		1
108	C6251A-15-02y	Gear		1
108	C6256A-15-02y	Gear		1
109	C6251A-05-11y	Gear		1
109	C6256A-05-11y	Gear		1
110	C6251A-15-01y	Gear		1
110	C6256A-15-01y	Gear		1
111	RUN6246-108015	Spacer		1
112	C6251A-15-02y	Gear		1
112	C6256A-15-02y	Gear		1
113	C6251A-05-07y	Gear		2
113	C6256A-05-07y	Gear		2
114	GB894.1-86	External Circlip	20	1
115	GB70-85	Screw	M6×70	2
116	RUN6246-106009	Plate		1
117	GB818-85	Screw	M5×8	2
118	C6251A-01-02	Bed Gap		1
119	GB70-85	Screw	M12×50	4
120	GB881-86	Bolt Pin	10×75	2
121	GB6170-86	Nut	M10	2
122	GB70-85	Screw	M10×40	2
123	GB70-85	Screw	M6×16	2
124	RUN6246-106059	Bracket		1
125	RUN6246-106053	Bracket		1
126	GB79-85	Screw	M8×30	2
127	GB6170-86	Nut	M8	2
128	Z16-1	Lever Bush	M12×40	1
129	C6251A-01-07-1	Bush		1
130	RUN6246-106010-4	Oil Plug		1
131	GB818-85	Screw	M5×8	3
132	RUN6246-106031	Cover		1

No.	Part No.	Name	Specification	Qty.
133	GB80-85	Screw	M6×8	1
134	GB80-85	Screw	M6×8	1
135	GB70-85	Screw	M6×35	4
136	RUN6246-106057A	Lever		1
137	RUN6246-106055	Pin		1
138	RUN6246-106058	Washer		1
139	Q81-1	Spring	1×6×20	3
140	RUN6246-106056	Bush		1
141	GB70-85	Screw	M8×20	4
142	GB70-85	Screw	M16×55	6
143	GB93-86	Washer	M16	6

MACHINERYHOUSE